

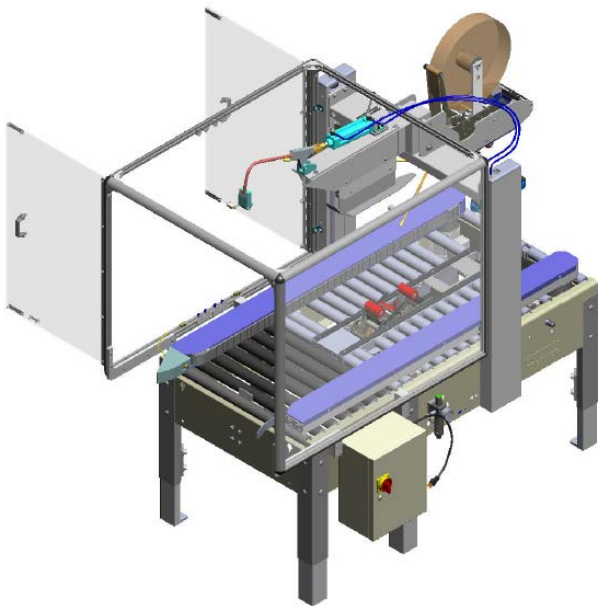

# USER MANUAL UA 262024-SB



For Serial Numbers:  
TM095 and TM595 XX X XXX



# TABLE OF CONTENTS

---

<b>Section 1</b>	<b>Table Of Contents</b>	<b>2</b>
<b>Section 2</b>	<b>Revision Control</b>	<b>3</b>
<b>Section 2</b>	<b>Technical and Field Assistance</b>	<b>4-5</b>
<b>Section 3</b>	<b>Warranty</b>	<b>6</b>
<b>Section 4</b>	<b>Description of the UA262024 CARTON SEALER</b>	<b>7-9</b>
<b>Section 5</b>	<b>Important Safeguards</b>	<b>10-17</b>
<b>Section 6</b>	<b>Specifications</b>	<b>18-21</b>
<b>Section 7</b>	<b>Set-Up Procedures</b>	<b>22-31</b>
<b>Section 8</b>	<b>Operating Instructions</b>	<b>32-35</b>
<b>Section 8</b>	<b>Troubleshooting</b>	<b>36</b>
<b>Section 9</b>	<b>Replacement Parts</b>	<b>37</b>
<b>Section 10</b>	<b>Optional Equipment</b>	<b>38</b>
<b>Section 11</b>	<b>Appendix</b>	<b>39</b>

# **REVISION CONTROL**

REV00

REV01

REV02

Initial Release

Second Release

Third Release

# TECHNICAL ASSISTANCE

---

## Technical Support

This is the Interpack Model UA262024 SB Carton Sealer you ordered. It has been set up and tested in our factory with Intertape manufactured water activated tapes. If any problems occur when setting up or operating this equipment, please contact the authorized distributor from where you purchased this item.

If contact with the authorized distributor is not possible, **Interpack Technical Support** is available. Should the need to contact **Interpack Technical Support** arise, please have the Case Sealer **model number and serial number** on hand. This information can be found on the nameplate of the side panel of the machine. Interpack Technical Support is available during normal business hours (Eastern Time).

### **PHONE 800-474-8273 Option 3**

If you have a technical question that does not require an immediate response, you may contact Interpack by fax.

### **FAX 800-462-1293**

Technical support may also be contacted via email at the address below:

### **EMAIL [Machsupp@itape.com](mailto:Machsupp@itape.com)**

## Replacement Parts

Order parts by item number, part description and quantity required. Replacement parts are available from your Authorized Interpack Distributor exclusively.

Should you require assistance selecting the correct part, you may call:

Intertape Polymer Group  
Interpack Machinery

Tel: 1-800-474-8273 Option 3  
Fax: 1-800-462-1293

MODEL: \_\_\_\_\_

SERIAL NUMBER: \_\_\_\_\_

DISTRIBUTOR PURCHASED FROM: \_\_\_\_\_

DATE OF PURCHASE: \_\_\_\_\_

UA262024 SB Manual  
UM095TW / UM595TW

## FIELD SERVICE ASSISTANCE

---

This machine is designed to provide years of trouble free operation. If any problems arise with this machine during the normal course of operation, your properly trained and qualified internal service personnel should be able to repair any issues after consulting the Troubleshooting section of this manual.

Service support is available from your Authorized Interpack Distributor at additional cost if the problem cannot be remedied after consulting the Troubleshooting section of this manual.

# WARRANTY

---

**EQUIPMENT WARRANTY AND LIMITED REMEDY:** The following warranty is made in lieu of all other warranties, express or implied, including, but not limited to, the implied warranty of merchantability, the implied warranty of fitness for a particular purpose, and any implied warranty arising out of a course of dealing, a custom or usage of trade:

Intertape sells its Interpack Tape Heads, Case Tapers and Case Erectors with the following warranties:

1. The HSD® 2000 Tape Heads' knife blades, springs and wipe down rollers will be free from all defects for a period of ninety (90) days.
2. All other HSD® 2000 Tape Head parts will be free from all defects for one (1) year after delivery.
3. Water Activated Tape Heads' blades will be free from defects for ninety (90) days after delivery.
4. Drive Belts will be free from defects for ninety (90) days after delivery.
5. The Gear Motors will be free from defects for one (1) year after delivery.
6. All other components for Case Tapers and Case Erectors will be free from defects for one (1) year after delivery.

If any part is proven defective within its warranty period, then the exclusive remedy and Intertape's and the seller's sole obligation shall be, at Intertape's option, to repair or replace the part, provided the defective part is returned immediately to Intertape's factory or an authorized service station designated by Intertape.

A part will be presumed to have become defective after its warranty period unless the part is received or Intertape is notified of the problem no later than five (5) calendar days after the warranty period.

If Intertape is unable to repair or replace the part within a reasonable time, then Intertape, at its option, will replace the equipment or refund the purchase price. Intertape shall have no obligation to install the repaired or replacement part.

Intertape shall have no obligation to provide or pay for the labor required to install the repaired or replacement part. Intertape shall have no obligation to repair or replace (1) those parts failing due to: operator misuse, carelessness, or due to any accidental cause other than equipment failure, or (2) parts

1. Failure or damage is due to misapplication, lack of proper maintenance, abuse, improper installation or abnormal conditions such as temperature, moisture, dirt or corrosive matter, etc.
2. Failure due to inadequate cleaning, improper operating environment, improper utilities or operator error.
3. Failure due to operations above the rated capacities, or in any other improper manner, either intentional or otherwise.
4. Failure is due to equipment, which has been altered by anyone other than an authorized representative of Intertape Polymer Group.
5. Failure is due to an attempt by the purchaser to correct alleged defective equipment. In this event the purchaser is responsible for all expenses incurred.

**LIMITATION OF LIABILITY:** Intertape and seller shall not be liable for direct, indirect, special, incidental or consequential damages based upon breach of warranty, breach of contract, negligence, strict liability or any other legal theory.

The foregoing Equipment Warranty and Limited Remedy and Limitation of Liability may be changed only by written agreement signed by authorized officers of Intertape and seller.

# DESCRIPTION OF UA262024 CARTON SEALER

The UA262024 machine (figure1) is designed to fold and tape carton tops. It is easy to set-up and to operate. It can be adjusted to a wide range of carton sizes.

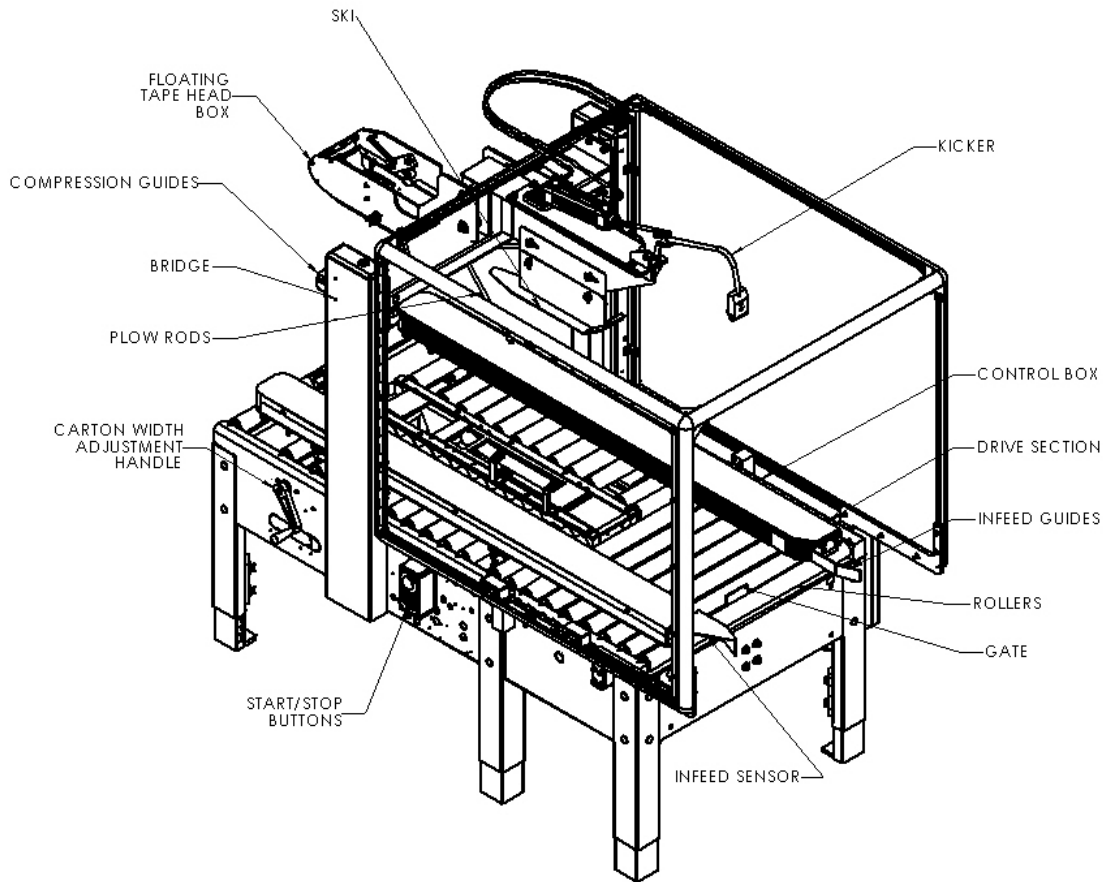

Figure 1

PART	FUNCTION
Start/Stop Buttons	Start and Stop (Emergency Stop) buttons
Rollers	Allows carton to slide through machine
Infeed Guides	Guide carton to feed belts
Gate	Stops carton to allow preceding carton to move forward
Infeed Sensor	Detects rear of carton, triggers gate and kicker action
Drive Sections	Carry carton through machine
Kicker	Folds rear minor flap
Ski	Folds front minor flap
Plow Rods	Fold major flaps
Compression Guides	Position major flaps before taping
Width Adjustment Handle	Adjusts Drive Section to obtain adequate pressure on carton
Bridge	Top moving part of machine.

# DESCRIPTION OF UA262024 CARTON SEALER

## How the UA262024 Works – Figures 2 & 3

When a new carton (item 1) reaches the Carton Sealer Machine rollers, it is pick-up by the Drive Sections (belts) (items 2) and carried forward into the machine. The sensor (item 3) detects carton which lowers the gate (item 4) to lets carton through. When sensor detects rear of carton, timer is turned on. When the time has elapsed, kicker (item 5) is triggered and folds rear minor flap. Front minor flap is folded by ski (item 6) as carton goes through. Major flaps are folded by plow rods (items 7) as carton is moved forward. Top and bottom flaps are taped simultaneously by top and bottom tape heads.

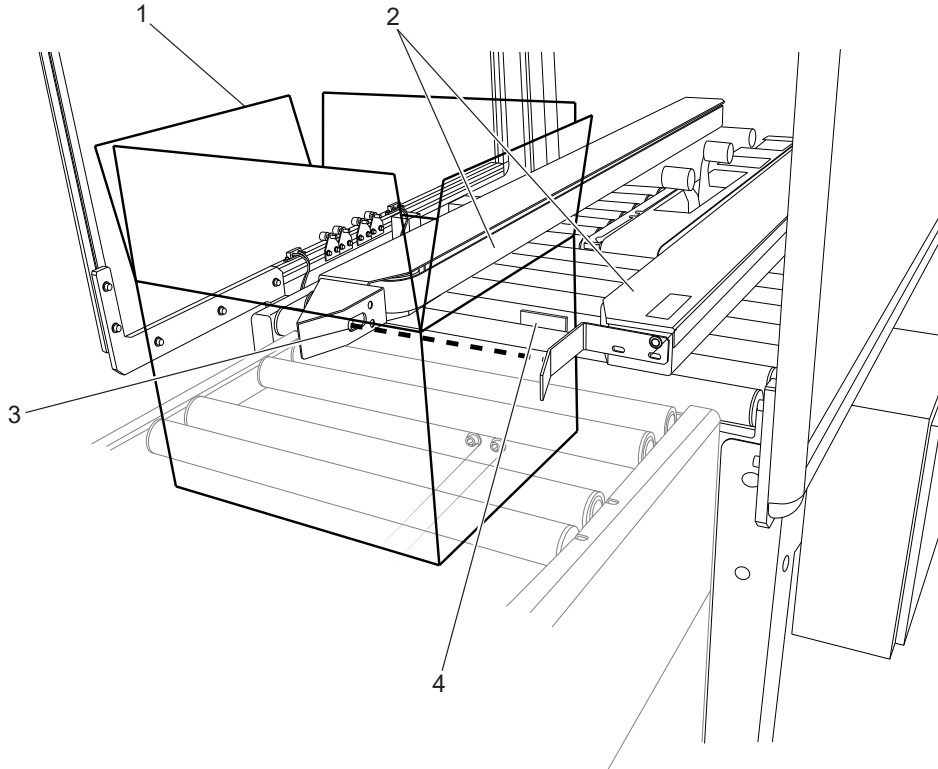

Figure 2

There is 2 styles of kicker assemblies see figure 3 on page 9 for more information



# DESCRIPTION OF UA262024 CARTON SEALER

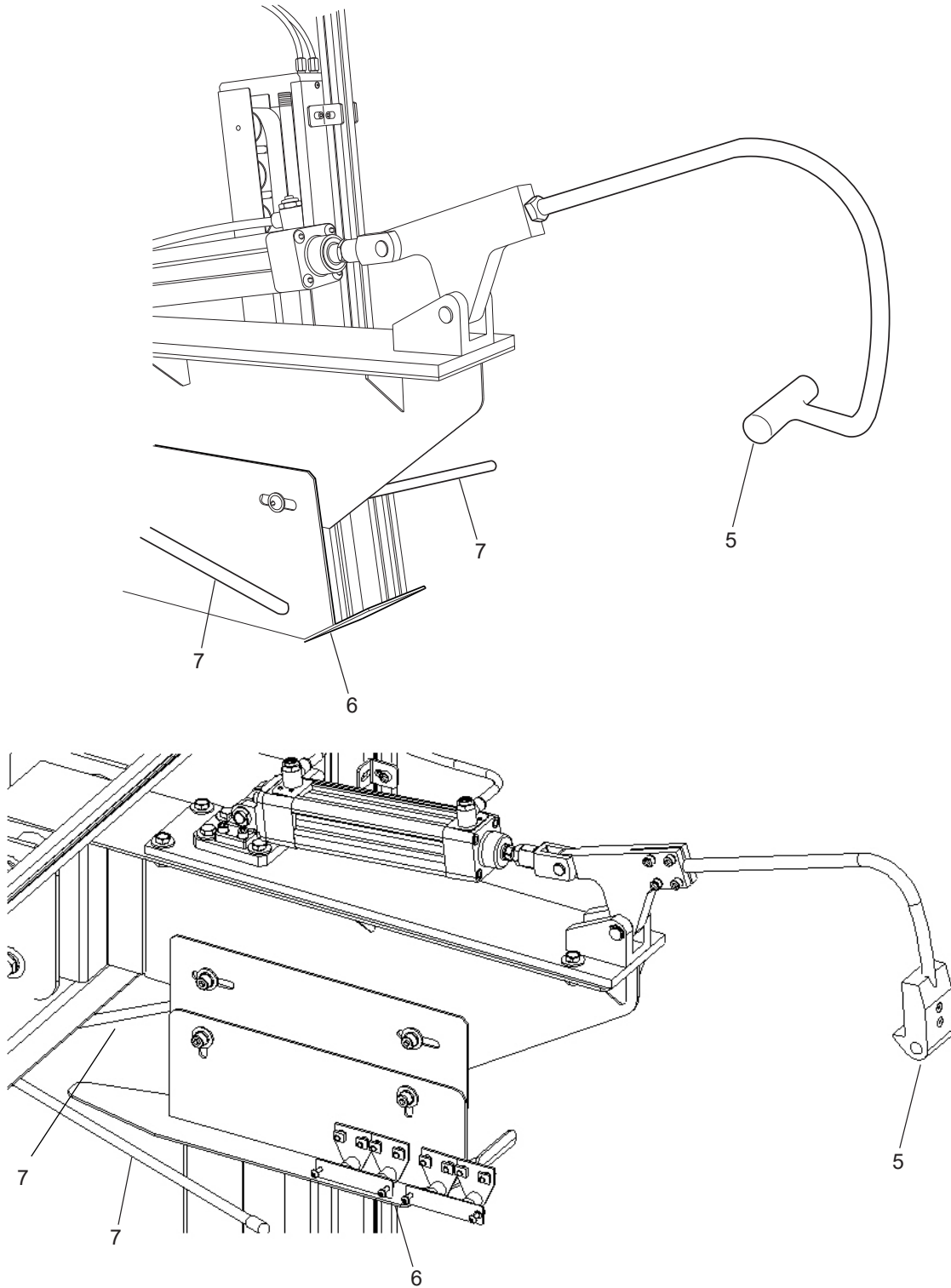

Figure 3

UA262024 SB Manual  
UM095TW / UM595TW

## Important Safeguards

There are a number of safety labels used on Interpack Carton Sealers. These labels are placed at different locations (refer to **Figure 2**) on the machine to warn operators and service personnel of possible dangers. Please read the labels on the machine and the following safety precautions before using the machine.

- ✓ Read this manual for other important safety operating and service information.
- ✓ Only trained personnel are to operate machine.
- ✓ Only fully qualified technicians are to service this machine.
- ✓ Wear safety glasses.
- ✓ Shut off power to machine before adjusting machine or loading & threading Tape Heads.
- ✓ Disconnect electrical power and compressed air (where applicable) before servicing.
- ✓ Follow Lock Out / Tag Out Procedures BEFORE servicing any machinery.
- ✓ All covers and guards must be in place before operating.
- ✓ Stay clear of moving parts which can shear and cut.

**Note:** Should any of the safety labels placed on the Case Sealer be damaged or destroyed, replacements are available through your distributor.

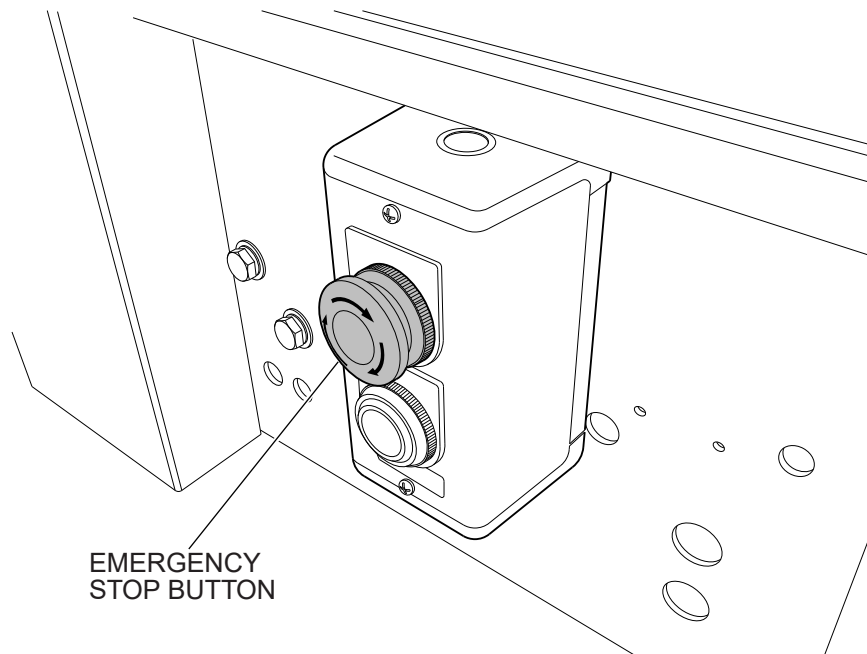

Figure 4 Emergency stop button

# Important Safeguards

## 2.2 Safety decal location – Figure 5

The figure below shows where the safety decals are located on the machine. Replace any absent or illegible decal. Replacement decals can be found in the Parts section of this manual.

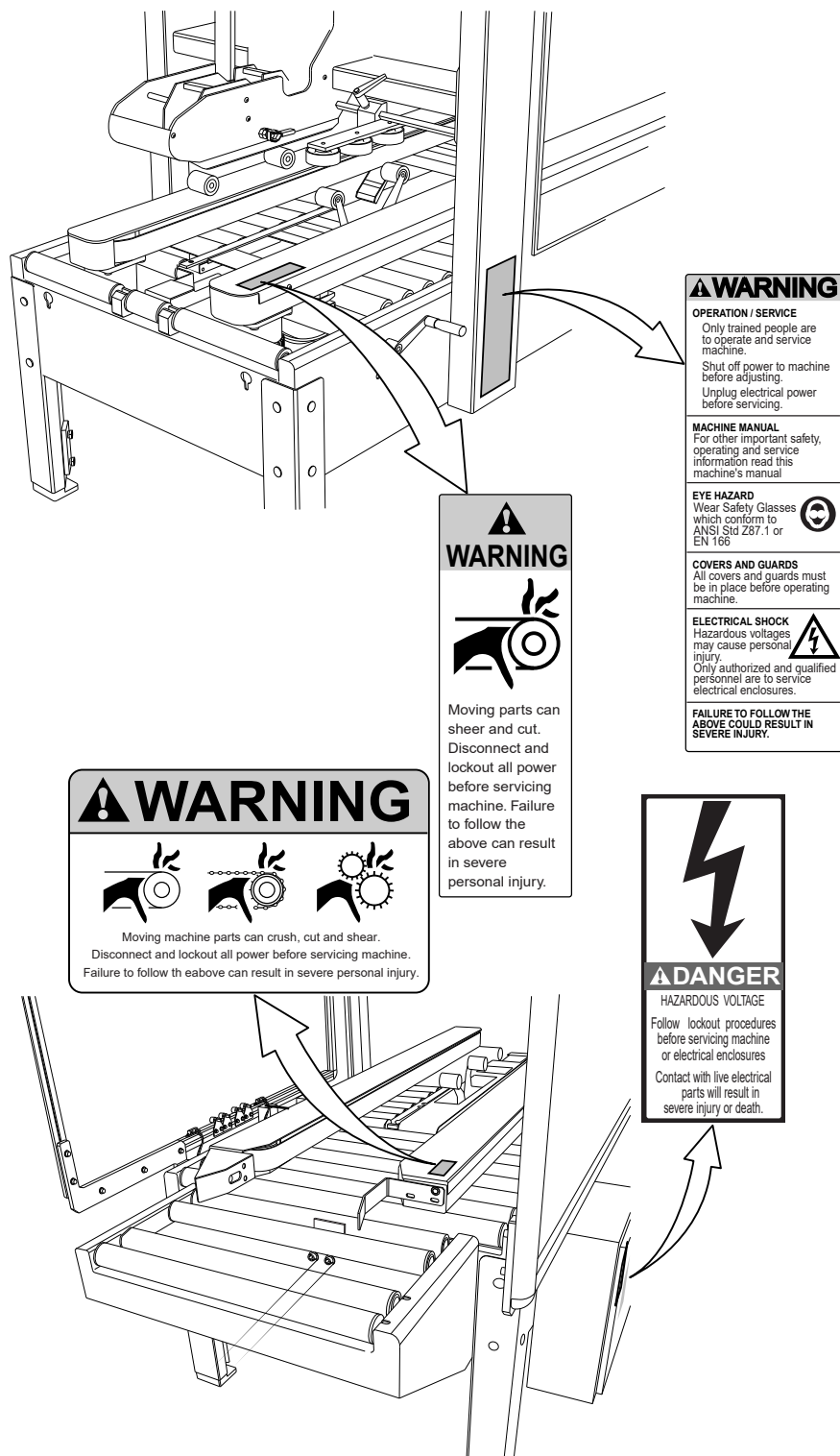





Figure 5 Safety Decal Location

UA262024 SB Manual  
 UM095TW / UM595TW

## Important Safeguards

**There Are A Number Of Safety Labels Used On Intertape Case Sealers.**

<p>The label shown is affixed to the upper tape head assembly on either side of the machine. It warns operators and service personnel of the presence of the cutting blade that may not be visible. Caution should be exercised when approaching this area.</p>	 <p>The label features a black silhouette of a hand reaching towards a saw blade. To the right, an orange box contains the word "WARNING" in black. Below this, the text reads: "Blade hazard. Keep hands clear. Follow lock-out procedures before servicing."</p>
<p>The label shown is affixed to the top squeezer assembly brackets on either side of the machine if installed. The squeezer assembly is optional. They warn the operator of a potential pinch point between the top of the case and the top squeezer rollers. Keep hand away from this area when processing a case.</p>	 <p>The label is a black triangle containing a black silhouette of a hand being caught between two rollers. An arrow points to the right, indicating the direction of the case being processed.</p>
<p>This label affixed to the electrical control box and control box advises service personnel to connect the machine to a properly grounded outlet.</p>	 <p>The label has a yellow background with a black border. At the top, a black triangle contains the word "CAUTION" in black. Below this, the text reads: "To provide continued protection against risk of electric shock, connect to properly grounded outlets only."</p>
<p>The label shown is attached to the electrical control box. The label warns the service personnel to unplug the power supply before attempting any service work on the case sealer.</p>	 <p>The label features a yellow triangle with a black lightning bolt symbol. To the right, an orange box contains the word "WARNING" in black. Below this, the text reads: "Hazardous voltage. Disconnect power before servicing."</p>

## Important Safeguards

The illustrated label shown is located on the “*infeed and exit*” ends of the machine belt drives. The label warns the operators and service personnel of the pinch point at each end of the belt drives.

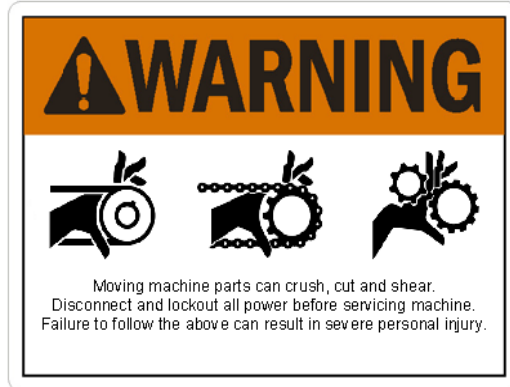



This label advises personnel about the dangers of the machine due to compressed air used in the system. Be aware of warnings and proper procedures when running and/or servicing the machine.



## Important Safeguards

The illustrated label shown is located on the side of the column. This label provides convenient safety instructions for the operator and service personnel in the operation of the Intertape Case Sealing Equipment.

<b>⚠ WARNING</b>	
OPERATION / SERVICE	
<ul style="list-style-type: none"> <li>Only trained people are to operate and service machine.</li> <li>Shut off power to machine before adjusting.</li> <li>Unplug electrical power before servicing.</li> </ul>	
MACHINE MANUAL	
For other important safety, operating and service information read this machine's manual.	
EYE HAZARD	
Wear Safety Glasses which conform to ANSI Std. Z87.1 or EN 166	
COVERS AND GUARDS	
All covers and guards must be in place before operating machine.	
COMPRESSED AIR	
Lock-out source and bleed off pressure before servicing equipment.	
ELECTRICAL SHOCK	
Hazardous voltages may cause personal injury. Only authorized and qualified personnel are to service electrical enclosures.	
FAILURE TO FOLLOW THE ABOVE COULD RESULT IN SEVERE INJURY.	

**Note:** Should any of the safety labels placed on the machine be damaged or destroyed, replacements are available.

## Important Safeguards

### Explanation of Signal Word Consequences

#### **Warning:**

Indicates A Potentially Hazardous Situation, Which If Not Avoided Could Result In Death Or Serious Injury Or Property Damage

#### **Caution:**

Indicates A Potentially Hazardous Situation, Which If Not Avoided Could Result In Minor Or Moderate Injury Or Property Damage

### **Warning**

- **To Reduce The Risk Associated With Mechanical, Pneumatic, and Electrical Hazards:**
  - a. Read, Understand, And Follow All Safety And Operating Instructions Before Operating Or Servicing The Case Sealer.
  - b. Allow Only Properly Trained And Qualified Personnel To Operate And Service This Equipment.
- **To Reduce The Risk Associated With Pinches, Entanglement And Hazardous Voltage:**
  - a. Turn Electrical Supply Off And Disconnect Before Performing Any Adjustments, Maintenance Or Servicing The Machine Or Taping Heads.
- **To Reduce The Risk Associated With Pinches And Entanglement Hazards:**
  - a. Do Not Leave The Machine Running While Unattended.
  - b. Turn The Machine Off When Not In Use.
  - c. Never Attempt To Work On Any Part Of The Machine, Load Tape, Or Remove Jammed Boxes From The Machine While The Machine Is Running.
- **To Reduce The Risk Associated With Hazardous Voltage:**
  - a. Position Electrical Cord Away From Foot And Vehicle Traffic.
- **To Reduce The Risk Associated With Sharp Blade Hazards:**
  - a. Keep Hands And Fingers Away From Tape Cutoff Blades. The Blades Are Extremely Sharp.
- **To Reduce The Risk Associated With Fire And Explosion Hazards:**
  - a. Do Not Operate This Equipment In Potentially Flammable/Explosive Environments.
- **To Reduce The Risk Associated With Muscle Strain:**
  - a. Use The Appropriate Rigging And Material Handling Equipment When Lifting Or Repositioning This Equipment.
  - b. Use Proper Body Mechanics When Removing Or Installing Taping Heads That Are Moderately Heavy Or May Be Considered Awkward To Lift.

### **Caution**

- **To Reduce The Risk Associated With Pinch Hazards:**
  - a. Keep Hands Clear Of The Upper Head Support Assembly As Boxes Are Transported Through The Machine.
  - b. Keep Hands, Hair, Loose Clothing, And Jewelry Away From Box Compression Rollers.
  - c. Always Feed Boxes Into The Machine By Pushing Only From The End Of The Box.
  - d. Keep Hands, Hair, Loose Clothing, And Jewelry Away From Moving Belts And Taping Heads.

## Important Safeguards

### Warning

- **To Reduce The Risk Associated With Mechanical, Pneumatic, and Electrical Hazards:**
  - a. Allow Only Properly Trained And Qualified Personnel To Operate And Service This Equipment.

### Operator Skill Level Descriptions

#### **Skill “A”: Machine Operator**

This Operator Is Trained To Use The Machine With The Machine Controls, To Feed Cases Into The Machine, Make Adjustment For Different Case Sizes, To Change The Tape And To Start, Stop, And To Re-Start Production

**Important: The Area Supervisor Must Ensure That The Operator Has Been Properly Trained On All Machine Functions Before Operating The Machine.**

#### **Skill “B” Mechanical Maintenance Technician**

This Technician Is Trained To Use The Machine As The Machine Operator And In Addition Is Able To Work With The Safety Protection Disconnected, To Check And Adjust Mechanical Components, To Perform Maintenance Operations And Repair The Machine. He Is Not Allowed To Work On Live Electrical Components

#### **Skill “C” Electrical Maintenance Technician**

This Technician Is Trained To Use The Machine As The Machine Operator And In Addition Is Able To Work With The Safety Protection Disconnected, To Check And Adjust Mechanical Components, To Perform Maintenance Operations And Repair The Machine. He Is Allowed To Work On Live Electrical Panels, Terminal Blocks And Control Equipment.

#### **Skill “D” Manufacturers Technician**

Skilled Technician Sent By The Manufacturer Or Its Agent To Perform Complex Repairs Or Modifications, When Agreed With The Customer



## Important Safeguards

### Operators Skill Level Required To Perform The Following Tasks On The Machine

Operation	Machine Condition	Operator Skill Level	Number Of Operators
Machine Installation & Set Up	Running With Safety Protections Disabled	B & C	2
Tape Roll Replacement	Stopped By Pressing The Emergency Stop Button	A	1
Blade Replacement	Electrical Power Disconnected	B	1
Drive Belt Replacement	Electrical Power Disconnected	B	1
Ordinary Maintenance	Electrical Power Disconnected	B	1
Extraordinary Mechanical Maintenance	Running With Safety Protections Disabled	D	1
Extraordinary Electrical Maintenance	Running With Safety Protections Disabled	C	1

# SPECIFICATIONS

## UA262024 SB Carton Sealer Machine Dimensions

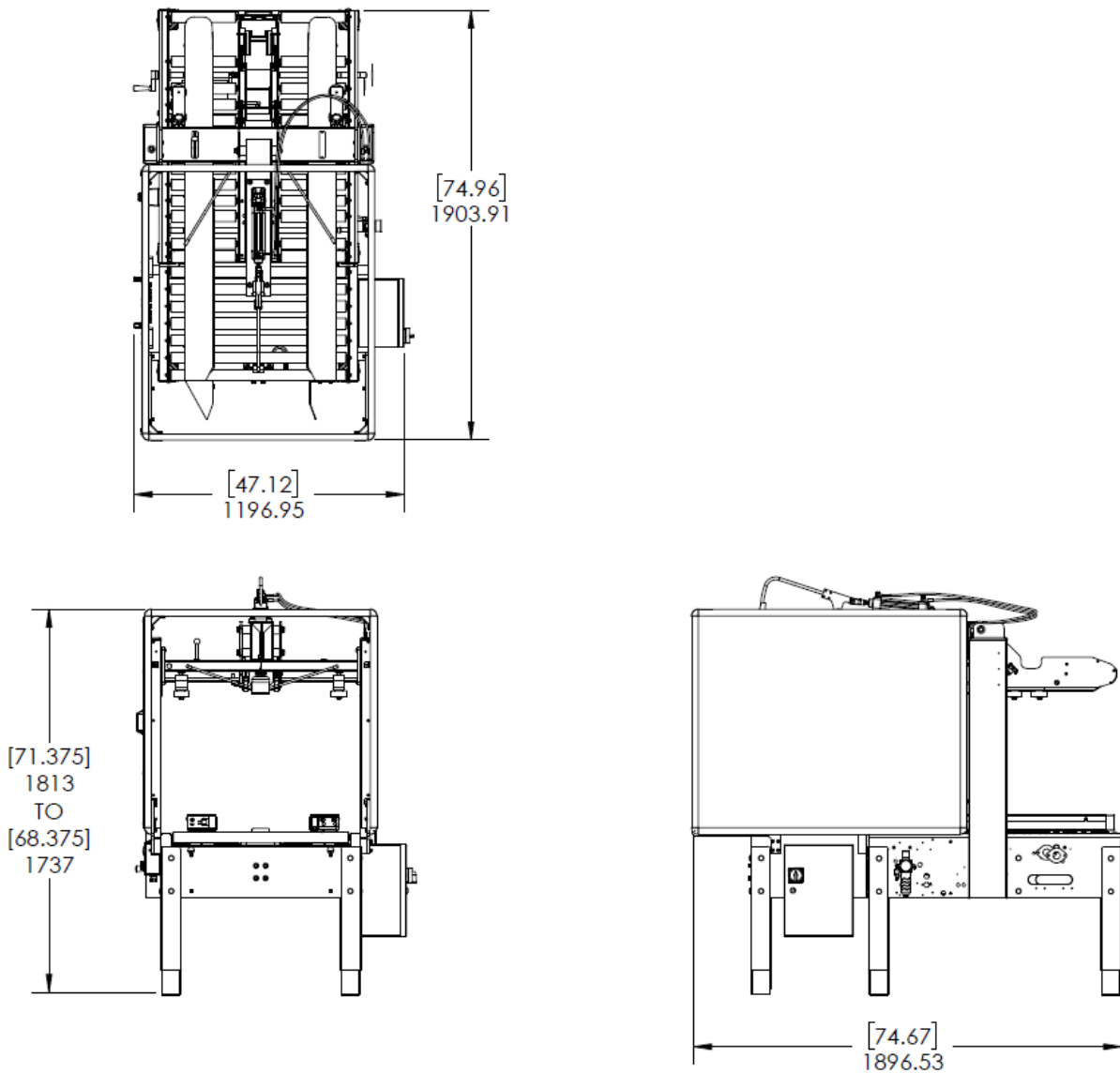

Figure 6 Machine Dimensions

**Machine Weight:** 701 lbs. (318 kg ) crated

UA262024 SB Manual  
UM095TW / UM595TW

# SPECIFICATIONS

## 1. Operating Conditions

Use in a dry, relatively clean environment at 40° to 105° F (5° to 40° C) with clean dry cartons. Machine must be set on a level surface or adjusted to operate on a level plane.

## 2. Power Requirements

Electrical - 115 V, 60 HZ, 7.6 A (400 Watts)

The UA262024 machine requires clean and lubricated air to function properly.

Compressed Air – 60 PSI

Air intake fitting size: 3/8”

This machine comes standard with a bottom gear motor, a top gear motor and an electrical box.

The electrical box contains a Start switch, the Emergency Stop switch, and a Starting Relay with a thermal over load and can be located on either side of the carton sealer for customer convenience (specify with order). A 1.8 meter standard three conductor power cord with plug is provided for 115V, 60HZ, 15 Amp service. The receptacle providing this service must be properly grounded. Before the machine is plugged into the receptacle, ensure that the switch is OFF and all materials are removed from the machine.

A twelve foot (12') standard three conductor power cord with plug is provided for **110V, 60HZ, 20 Amp** service. The receptacle providing this service **must** be properly grounded.

## 3. Operating Speed

Actual production rate is dependent on operator's dexterity and the case size mix. Boxes must be 14 inches apart. Belt Speed is 82 Ft/min.

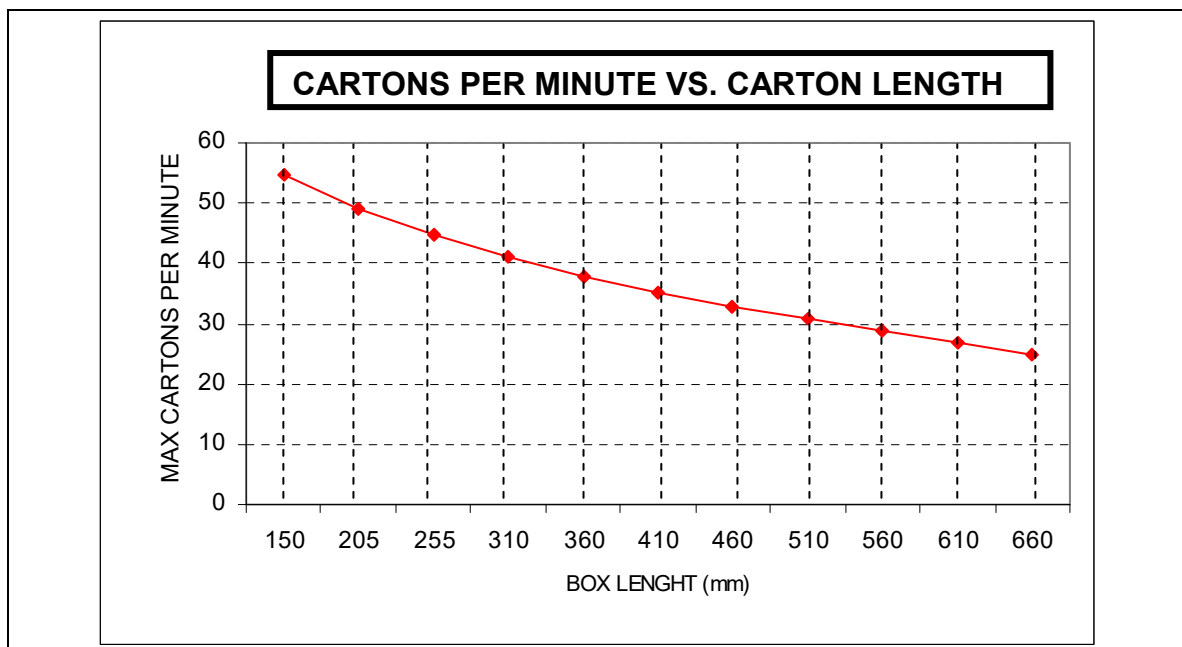

UA262024 SB Manual  
UM095TW / UM595TW

# SPECIFICATIONS

---

## 4. Tape Specifications

Use **Intertape Brand** Pressure Sensitive Carton Sealing Tape.

The machine can accommodate 2" (48mm) to 3" (75mm) wide tape.

A maximum tape roll diameter of 16 inches (405 mm) on a 3-inch (76.2 mm) diameter core can be installed on the tape head. (Accommodates all Intertape brand film tape machine roll lengths).

The standard Application Leg Length of 2.5 inches (+0.25", -0") (63.5 mm, +6.3 mm, -0 mm) is the factory set length. The tape head can be adjusted to an optional length of 2 inches (+0.25", -0") (50.8 mm, +6.3 mm, -0 mm). Refer to the Tape Head manual for adjustment of tape application leg length.

**Note: Machine should not be washed down or subjected to conditions causing condensation on components.**

**Note: For further specifications on the tape heads consult the tape head manual for your specific tape head.**

# SPECIFICATIONS

## 5. Carton Specifications

### Type

- Regular Slotted Containers (RSC)
- Other Style Cases May Be Processed. Consult Factory For Details.

### Material

125 To 275 PSI Bursting Test, Single Or Double Wall B Or C Flutes.

### Weight

85 lbs. Maximum (39 kg Max.)

### Size

- The case sealer can accommodate most cartons within the size ranges listed below.

Case Size			
Carton Size	Length	Width	Height
Minimum	152.4mm	88.9 (50mm tape) 114.3 (75mm tape)	114.3mm
Maximum	660.4mm	508mm	609.6mm

### Case Processing Stability

For optimal performance, the cases should be stable when processing through the machine. Unstable cases may tilt backwards upon contact with the upper tape head causing the machine to jam.

If the box length (in direction of seal) to box height ratio is .75 or less, then several boxes should be test run to assure proper machine performance. The formula is as follows;

$$\frac{\text{CARTON LENGTH IN DIRECTION OF SEAL}}{\text{CARTON HEIGHT}} > .75$$

# SET-UP PROCEDURES

## 1. Receiving and Handling

The machine is shipped to the customer fixed to a pallet. The machine is enclosed with either a corrugated sleeve and cap or an HSC corrugated box. The sequence below is step by step instructions to remove all packing materials.

- Remove the strapping securing the corrugated sleeve and cap or HSC corrugated box to the pallet.
- Lift off the cap and corrugated sleeve or HSC corrugated box.
- Remove protective wrapping from machine.
- Remove or relocate all securing devices such as tie wraps or locking collars.
- Remove the mounting bolts, which secure the machine to the shipping pallet.
- Remove machine from the pallet and re-locate to an area to prepare for final installation.

**WARNING!** Do not use a crane and chains to lift the machine. The machine could become unstable and cause material damage or serious injuries.

Remove all tie wraps and other shipping material from machine

**NOTE:** After unpacking the machine, look for any damage that may have occurred during shipping. Should the machine be damaged, file a claim with the transport company and notify your Intertape representative.

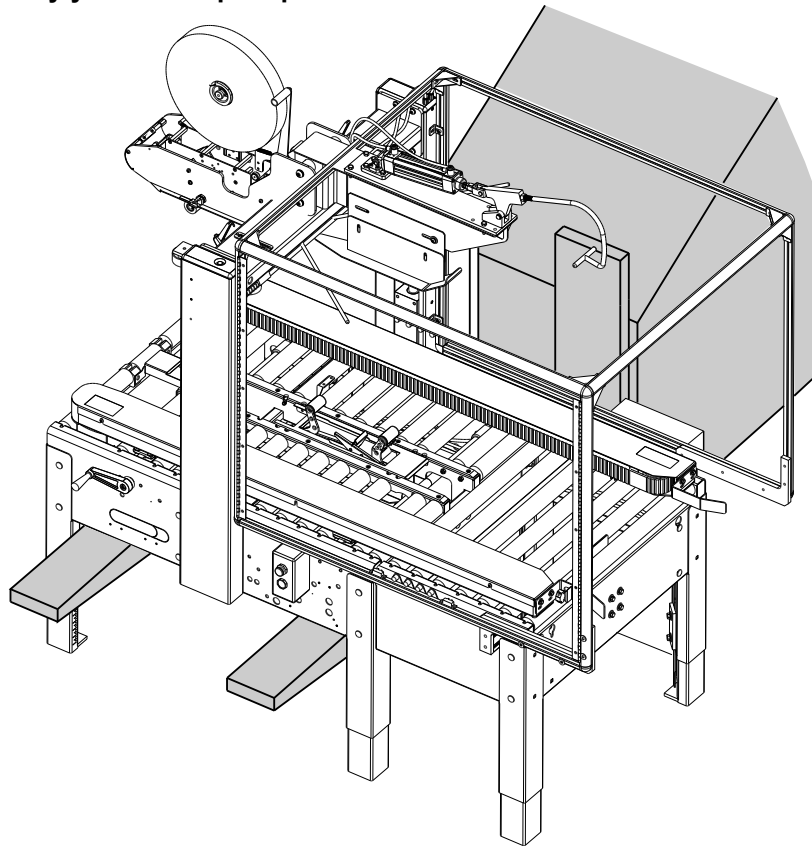

*Figure 7 Use fork lift to handle machine*

UA262024 SB Manual  
UM095TW / UM595TW

# SET-UP PROCEDURES

## 2. Machine Height Adjustment

Follow this procedure to adjust the height of machine:

- Make sure machine is installed on near level ground
- Use adjustable legs (figure 8) to adjust machine height and level. Machine height should be adjusted to incoming conveyor height.

To adjust leg height:

- A. Loosen bolts (item 2)
- B. Pull leg (item 1) to desirable length
- C. Tighten bolts (item 2)

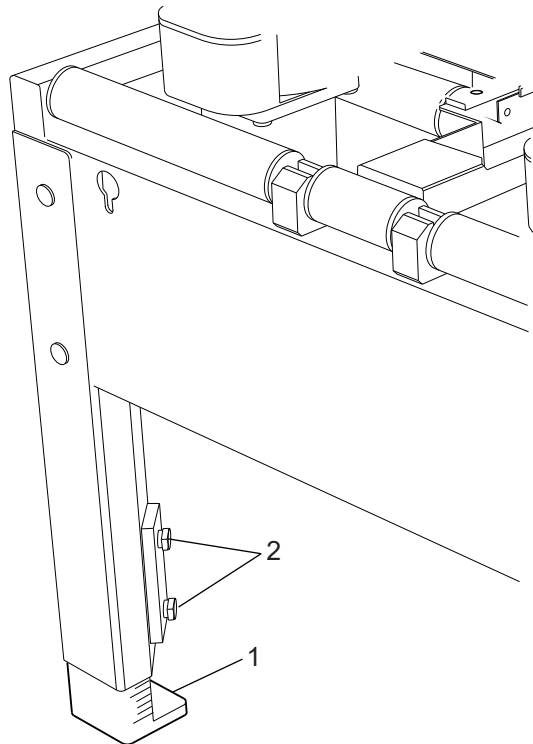

Figure 8 Adjustable legs

## 3. Pneumatic connection

This machine is pneumatically powered. An air supply must be connected to the Air Intake Filter/Regulator as shown in figure 9. Air must be clean and lubricated.

**Minimum required air pressure: 60 psi (4.1 bar)**

**Air intake fitting size: 3/8"**

To adjust air pressure:

- A. Pull adjustment knob
- B. Turn adjustment knob clockwise to increase pressure
- C. Push back knob

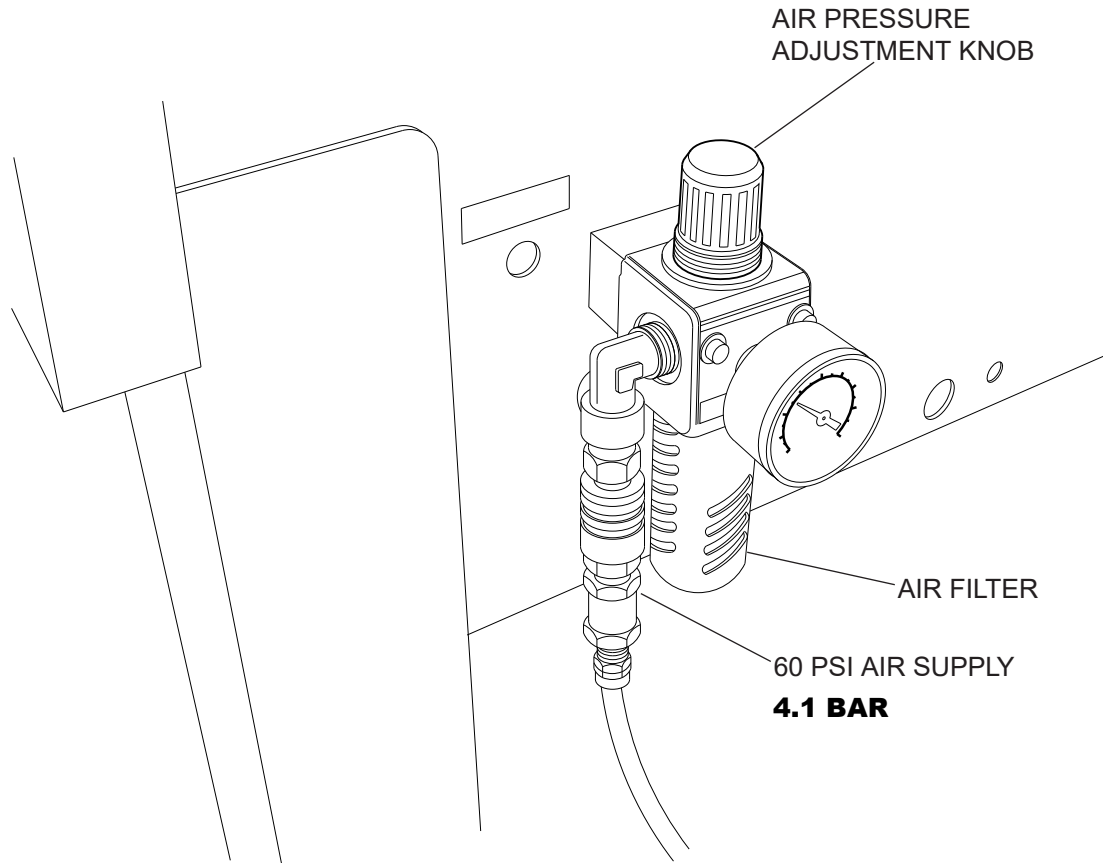

Figure 9 Pneumatic connection

## 4 Height and Width Adjustment

The UA262024 is designed to handle a full range of carton sizes. Follow these procedures to set-up the machine to the proper carton length and width.

### Height adjustment:

- A. Press the emergency stop button (figure 4) to shut-off machine.
- B. Unlock the bridge using the bridge lock lever (figure 10).
- C. Raise the bridge manually, enough to clear the height of a carton.
- D. Set a carton on the machine, as shown in figure 11. Make sure orientation of box is correct.
- E. If you plan on over-filling the cartons, unlock the floating mechanism on the tape head as shown in figure 11. Otherwise, make sure floating mechanism is locked.



## SET-UP PROCEDURES

---

**Note:** The purpose of the floating head is to absorb the pressure caused by over-filled cartons.

**F.** Lower the bridge manually until it is well rested against the carton, without squeezing it down.

**G.** Lock the bridge using the bridge lock lever (figure 10). Make sure to hold the bridge down while locking it.

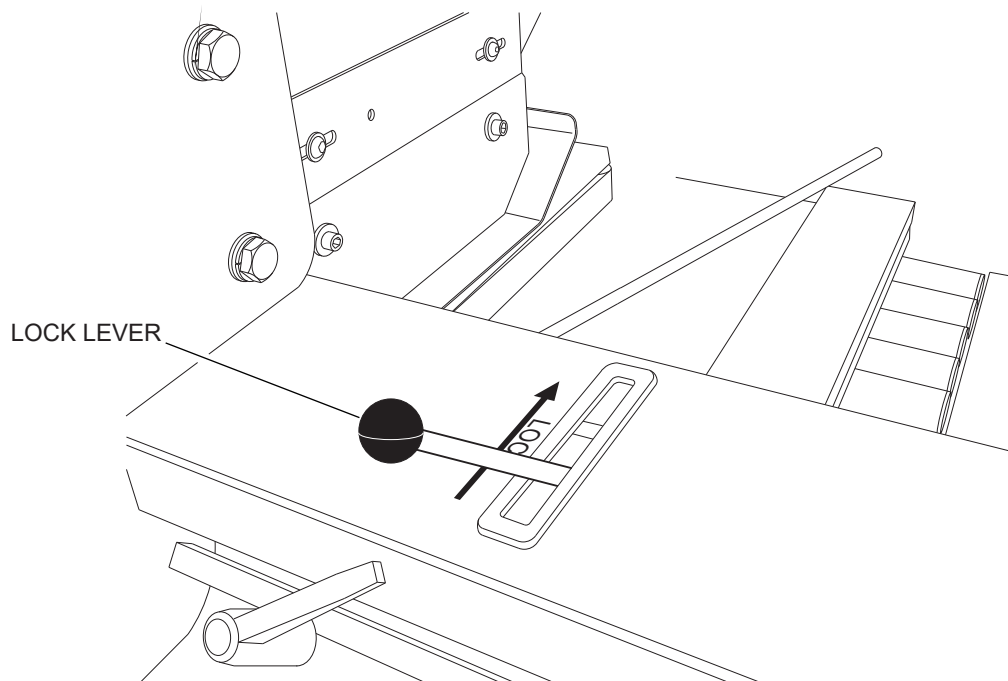

*Figure 10*

## SET-UP PROCEDURES

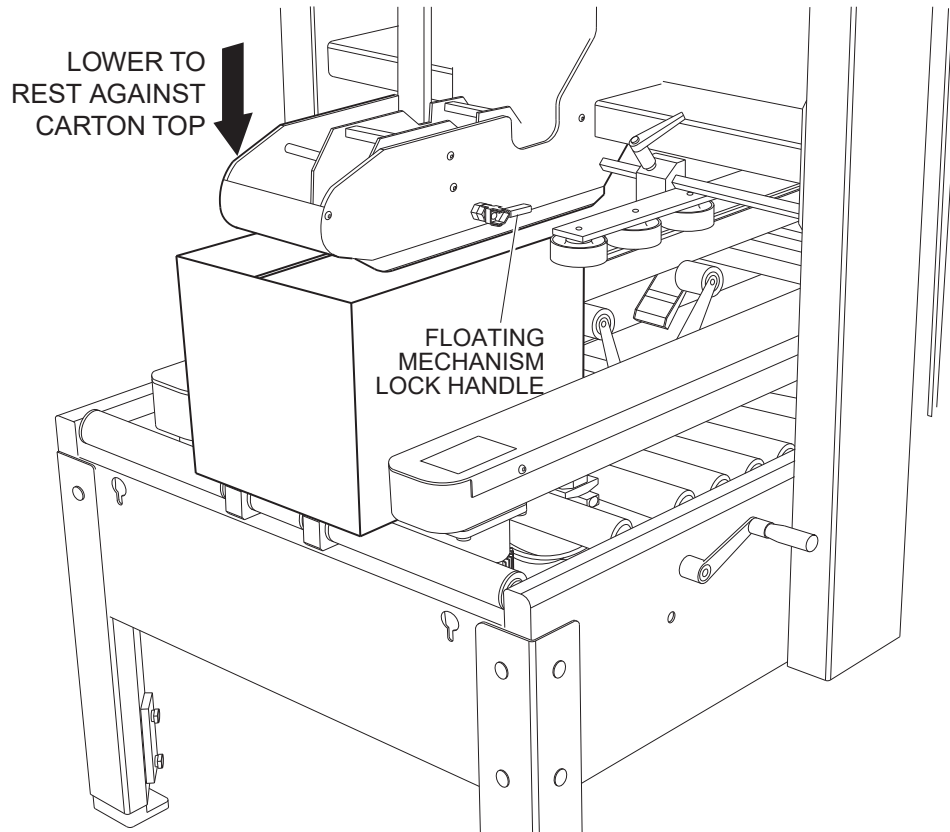

Figure 11

### Width adjustment:

1. Press the emergency stop button (figure 4) to shut-off machine.
2. Use the width adjustment handle to spread the drive sections, enough to clear a carton.
3. Set a carton on the machine, as shown in figure 12.
4. Use the width adjustment handle to move the drive sections closer together until they lightly squeeze the carton, as shown in figure 12.

**NOTE:** The carton must only be slightly squeezed by the drive sections

# SET-UP PROCEDURES

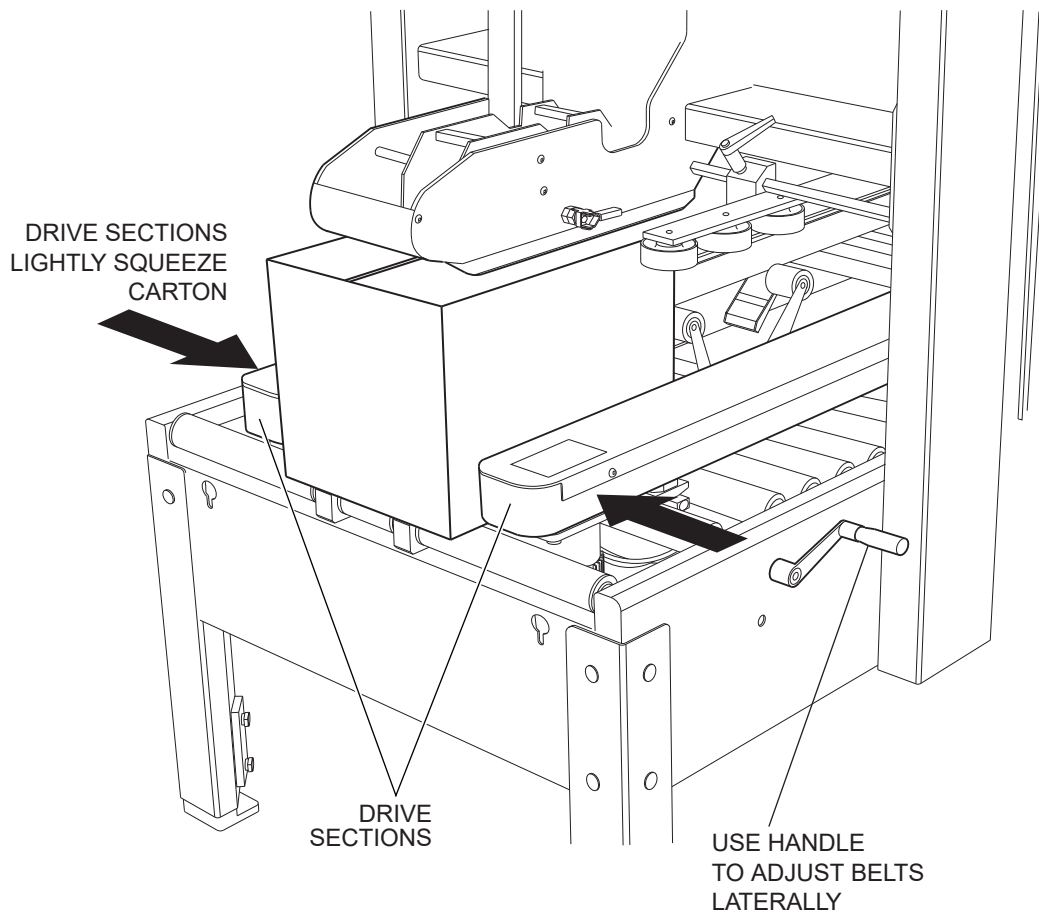

*Figure 12 Width adjustment*

**NOTE: When width and length adjustments are completed, pull up emergency stop button to turn machine back on.**

## **5 Compression Guides Adjustment (figure 13)**

Compression guides (figure 13) must be adjusted to lightly squeeze the upper part of the carton. This allows the two major flaps to contact each other and therefore insures a better seal. To adjust, loosen the handle then slide guide laterally until pressed against box.

# SET-UP PROCEDURES

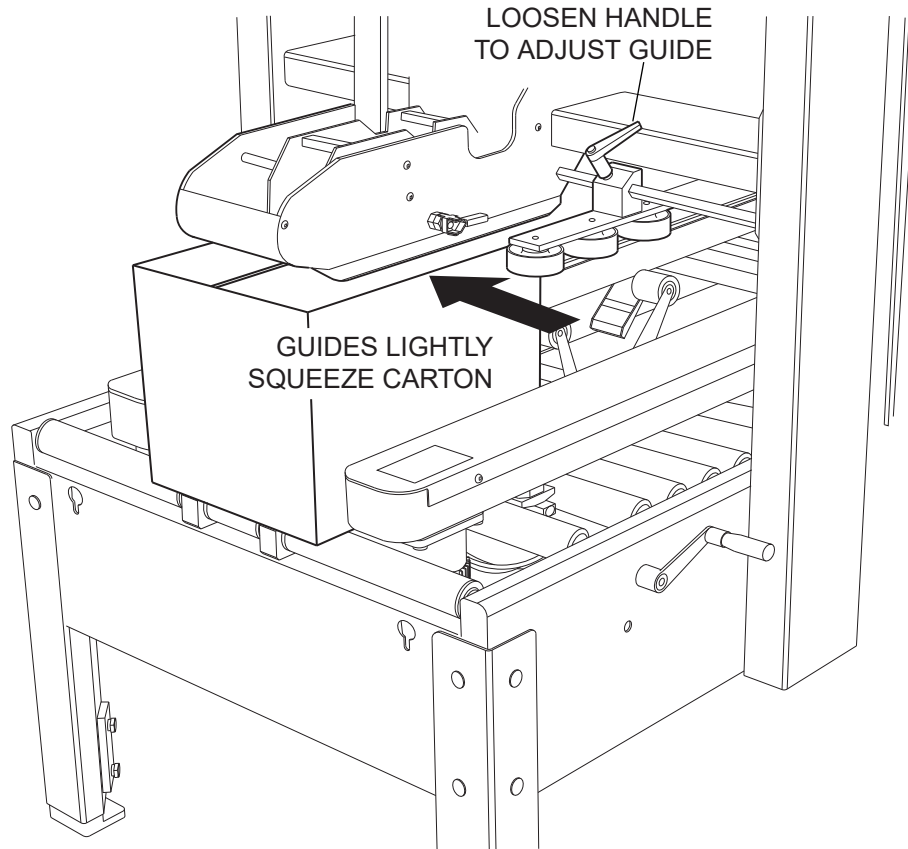

Figure 13

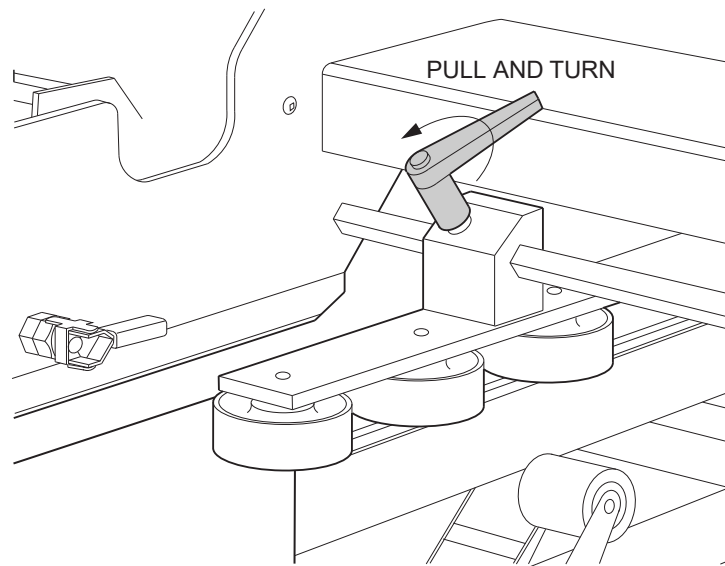

Figure 14

UA262024 SB Manual  
UM095TW / UM595TW

# SET-UP PROCEDURES

## 6 Kicker Adjustment (Figures 15 & 16)

Kicker must be adjusted so that rear minor flap is folded correctly. The kicker must be adjusted according to the flap length. The kicker is factory adjusted to work with an average size carton. If you are operating with longer flaps (20" cartons), the kicker must be shortened so it does not interfere with the carton waiting behind. Shorten i

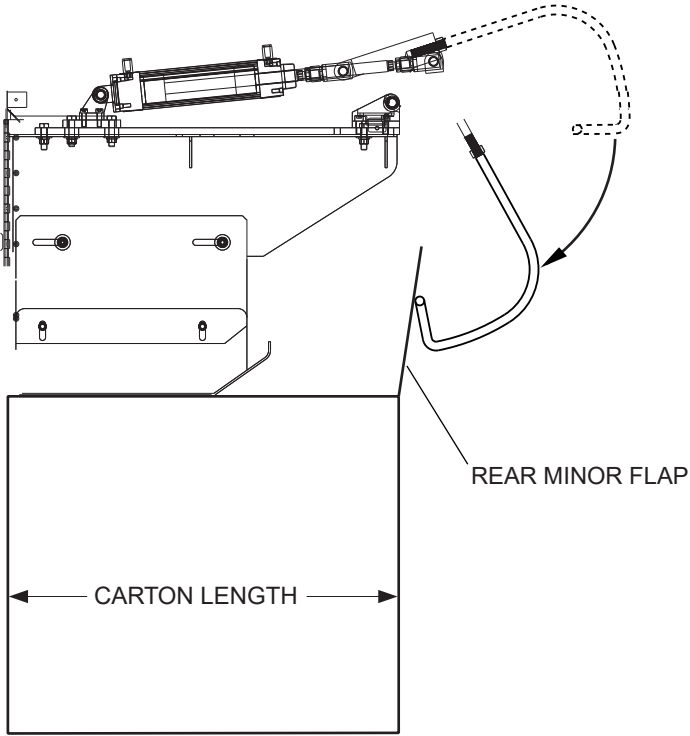
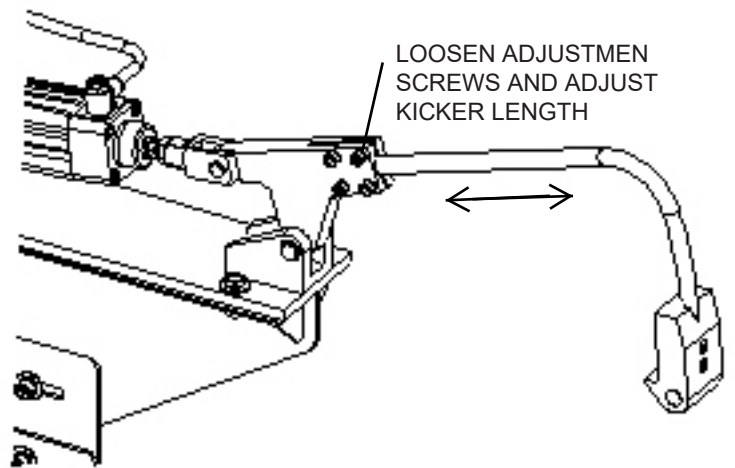
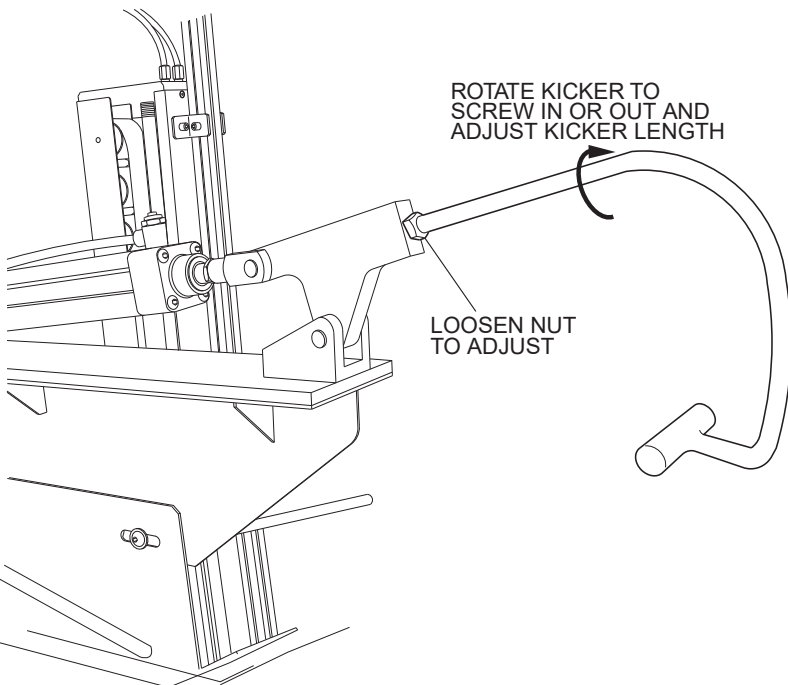
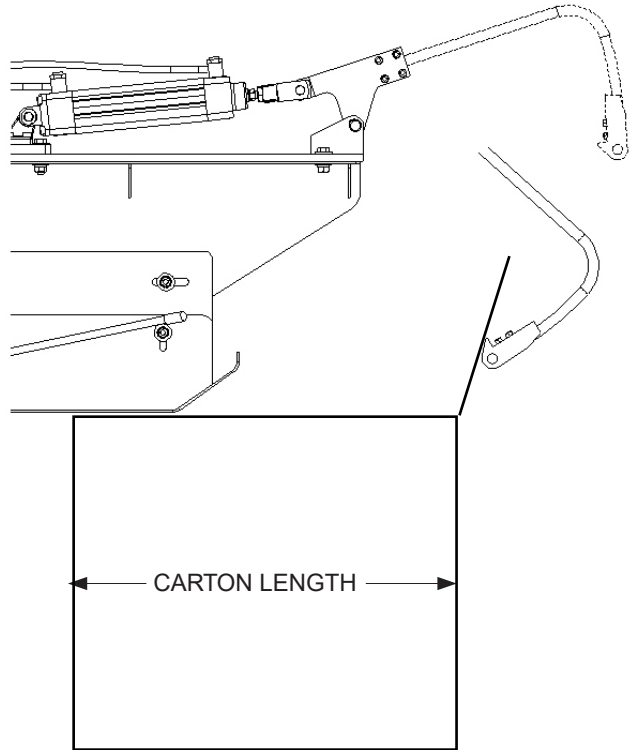

Figure 15



# SET-UP PROCEDURES

Figure 16

## 7 Plow Rod Adjustment

The plow rods are used for folding the major flaps. As the carton passes through the machine, the plow rods apply pressure to both flaps. The rods should be adjusted to obtain 90 degrees between each other, as shown in figure 17. For small cartons, reduce angle to approx. 70 degrees.

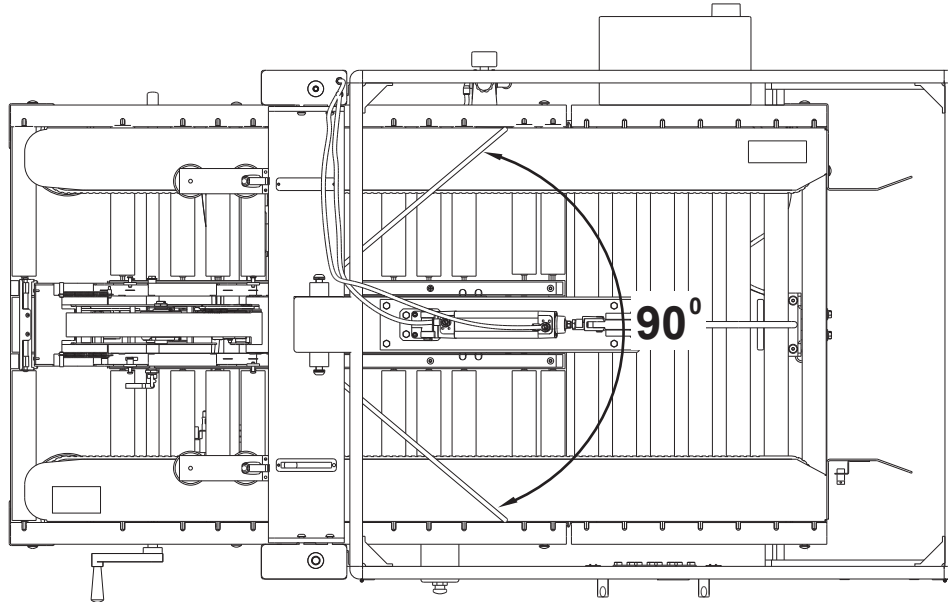

Figure 17 Plow Rod adjustment

## 8 Ski Adjustment (figure 18)

The ski is used for folding front minor flap. As the carton passes through the machine, the ski applies pressure to the front minor flap to fold it. The ski can be adjusted both vertically and horizontally. The vertical adjustment is done according to the carton height. The horizontal adjustment is done according to the carton width. For narrow boxes, move ski forward to allow rear flap to reach the ski.

To adjust ski vertically:

1. Raise ski enough to clear carton.
2. Set carton underneath ski.
3. Loosen the two screws and lower ski onto carton.
4. Tighten screws.

# SET-UP PROCEDURES

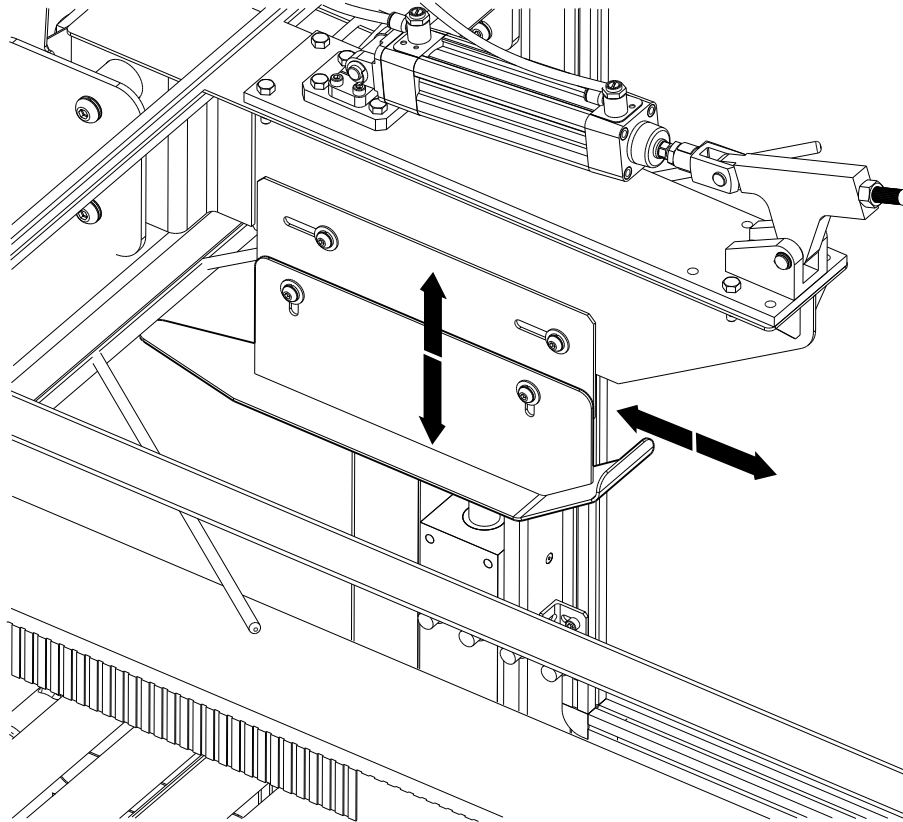

Figure 18 Ski adjustment

# OPERATING INSTRUCTIONS

**WARNING!** For safe operation of the UA262024, you must be a qualified and authorized operator. To be qualified, you must read and understand the written instruction supplied in the Operator's manual and know the safety rules and regulations for the job.

**NOTE:** Use only new cartons on this machine. Old or used cartons may prevent the machine from working properly.

## 1 Start and stop

A. Press the START button (figure 19)

B. To stop machine, press the STOP button.

**NOTE:** The machine will not start until the STOP button is released. To release the STOP button, turn button clockwise and pull.

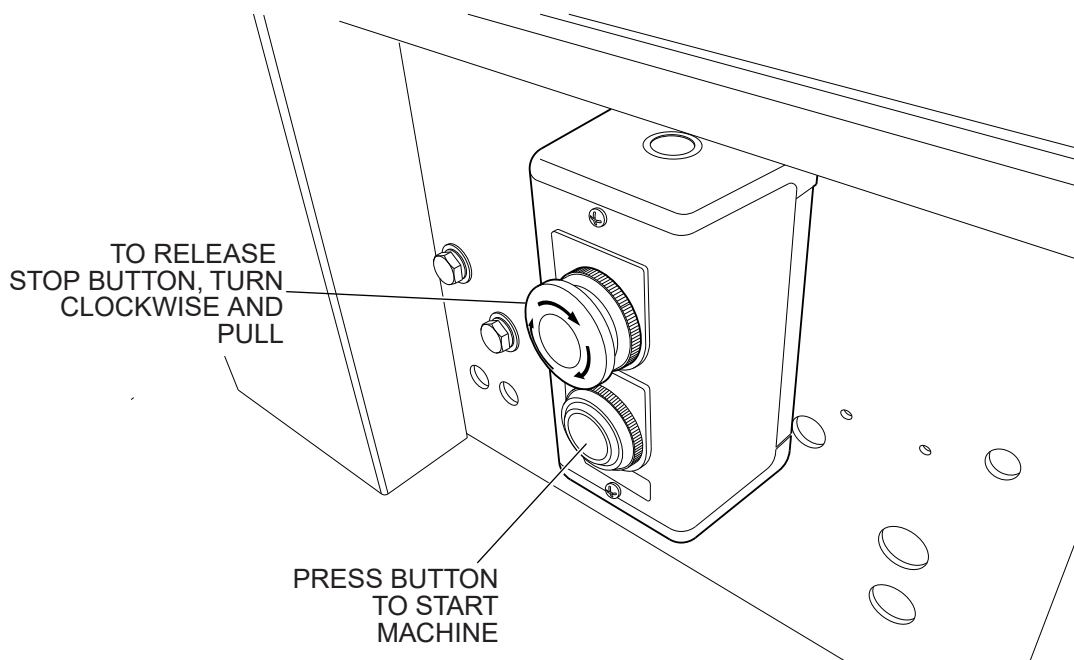

*Figure 19 Start and stop buttons*

## 2 Limit switches

The UA262024 is equipped with 3 limit switches (figure 20) located under the machine. As the carton width is modified (section 4.4), these preset limit switches, which are connected to the PC controller in the control box, will modify the delay (through timers) between the cartons. This delay affects the drive sections which move the cartons



# OPERATING INSTRUCTIONS

---

forward and the kicker which folds the rear flap. You do not need to adjust these limit switches and it is strongly recommended NEVER to adjust the PC controller.

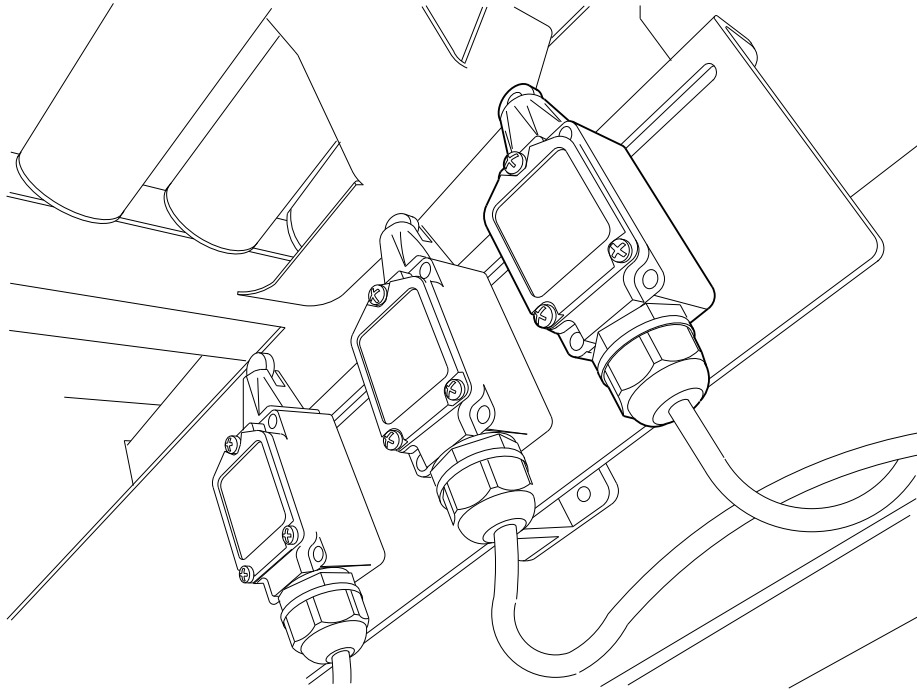

*Figure 20 Limit Switches*

# OPERATING INSTRUCTIONS

The UA262024 is a pneumatic machine and requires minimum maintenance. Bearings and cylinders are sealed and require no lubrication. The only maintenance required is listed below.

- Regularly clean the machine using pressured air to remove carton dust from the moving parts.

**WARNING! Always wear safety glasses when using pressured air.**

- Clean or change the air filter (figure 9) when necessary. Refer to the Spare Parts section of this manual for air filter part number.

- Replace conveyor belts (figures 21 & 22) when worn out or too loose. To replace a belt:

**WARNING! ALWAYS TURN POWER OFF BEFORE REPLACING BELT**

1. **Turn power off and disconnect power cord.**
2. Remove belt cover by loosening both screws (item 1) and lifting cover.
3. Remove belt manually (DO NOT loosen tension mechanism (item 2)).  
**NOTE:** Remove belt first on motor side.
4. Install new belt. Install only bottom portion of belt as shown in figure 22. The spinning of the belt will automatically lower the belt in place.

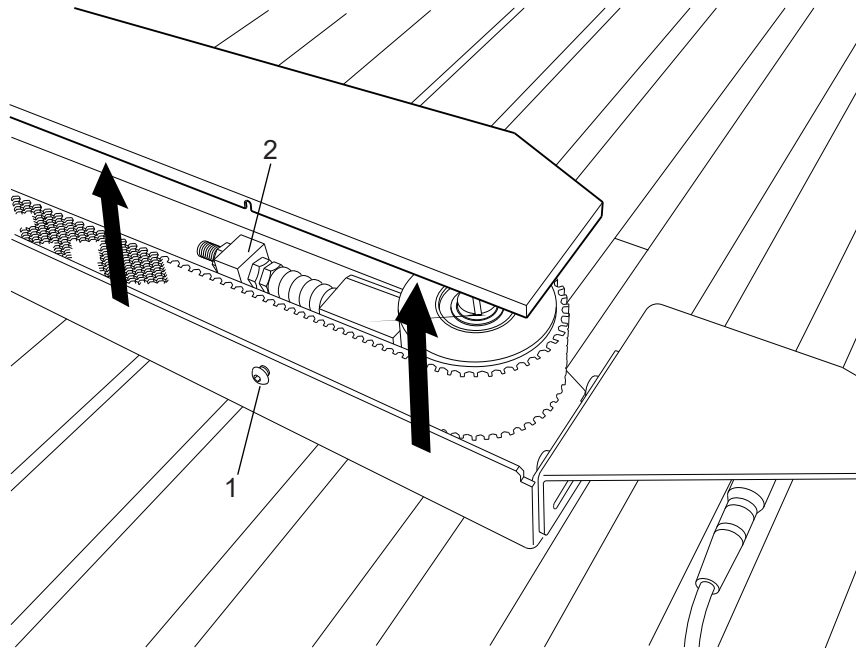
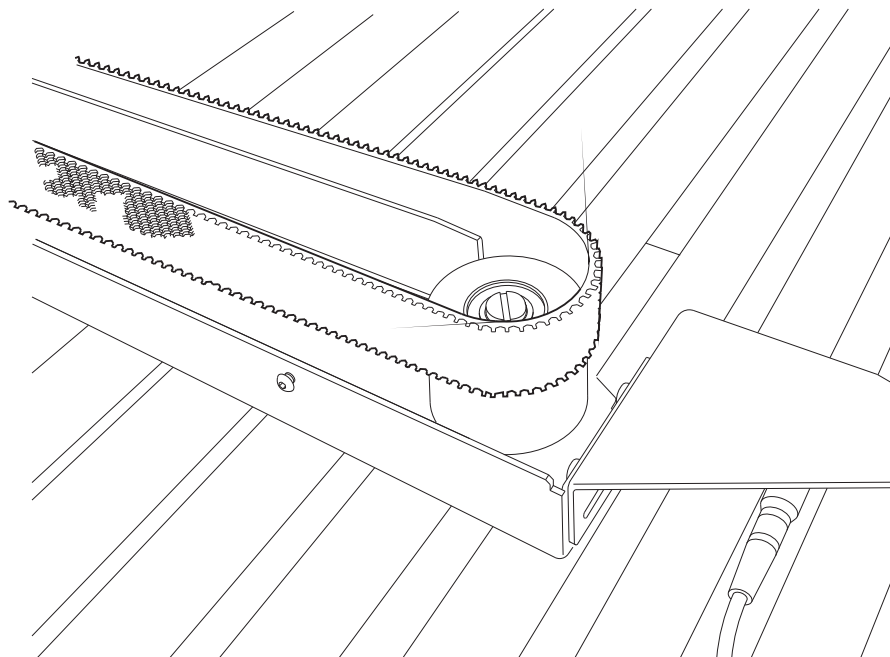

Figure 21 Remove Cover

# OPERATING INSTRUCTIONS

---



*Figure 22 Install new belt*

# TROUBLESHOOTING

PROBLEM	POSSIBLE CAUSE AND SOLUTION
Nothing happens when carton reaches infeed conveyor	No air in system. Make sure air connection is made and air pressure is sufficient Emergency stop button pressed down. Pull up button.
Conveyor belts are working but carton is not moving	Belts are not adjusted to squeeze box sufficiently. Adjust conveyor belt width. Check doors. Make sure doors are closed.
Single Locking System is locked, still the Bridge of Top Tape Head Box is loose on one side	Brass pin is worn out and has lost contact with column shaft.  Lock Tape Head Box at its maximum height, exceptionally with air supplied and at mode 3 (Hi-start).  On loose side, under the bridge, remove socket completely from screw head, unscrew flange screw with 3/4" key, replace flange screw and re-insert socket. Refer to Figure 23.
Carton does not go through	Check ski adjustment (section 4.7) Check tape head box height (section 4.6)

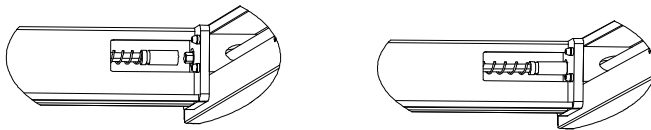

Figure 23

# REPLACEMENT PARTS

---

## Replacement Parts

Order parts by item number, part description and quantity required. Replacement parts are available from your Authorized Interpack Distributor exclusively.

Should you require assistance selecting the correct part, you may call:

Intertape Polymer Group  
Interpack Machinery

Tel: 1-800-474-8273 Option 3

Fax: 1-800-462-1293

## Field Service Assistance

This machine is designed to provide years of trouble free operation. If any problems arise with this machine during the normal course of operation, your properly trained and qualified internal service personnel should be able to repair any issues after consulting the Trouble Shooting section of this manual.

Service support is available from your Authorized Interpack Distributor at additional cost if the problem cannot be remedied after consulting the Trouble Shooting section of this manual.

**We recommend that you stock the following spare parts:**

DESCRIPTION	PART NUMBER	RECOMMENDED QUANTITY
Motor 1/3 hp, 115v 85 rpm universal	UPM7116	1
Belt, drive	UPM3544	2
Comp.spring swivel t.h. ass'y	UPM1068	2
Seal kit for 40mm iso cylinder	UPM3757	2
Filter for filter regulator unit	UPM3274	1
Fuse, 2 amps	UPM0002	1

## ***OPTIONAL EQUIPMENT***

---

<b>Model Number</b>	<b>Description</b>	<b>Item Number</b>	<b>Quantity Per Machine</b>
	Feed/Exit Table 16" (.4 M)	UM894T	1 or 2
	Feed/Exit Table 24" (.6 M)	UM998T	1 or 2
	Feed/Exit Table 36" (.9 M)	UM898T	1 or 2
	Heavy Duty Casters, set of 6	UM708	1 set of 6
	Secondary E-Stop	UM9003	1

## APPENDIX – ILLUSTRATIONS AND PARTS LISTS

---

Machine and Assemblies

A-1 through A-55

See next page for beginning of illustration and parts.

**BASE ASSEMBLY  
(USM6104)**

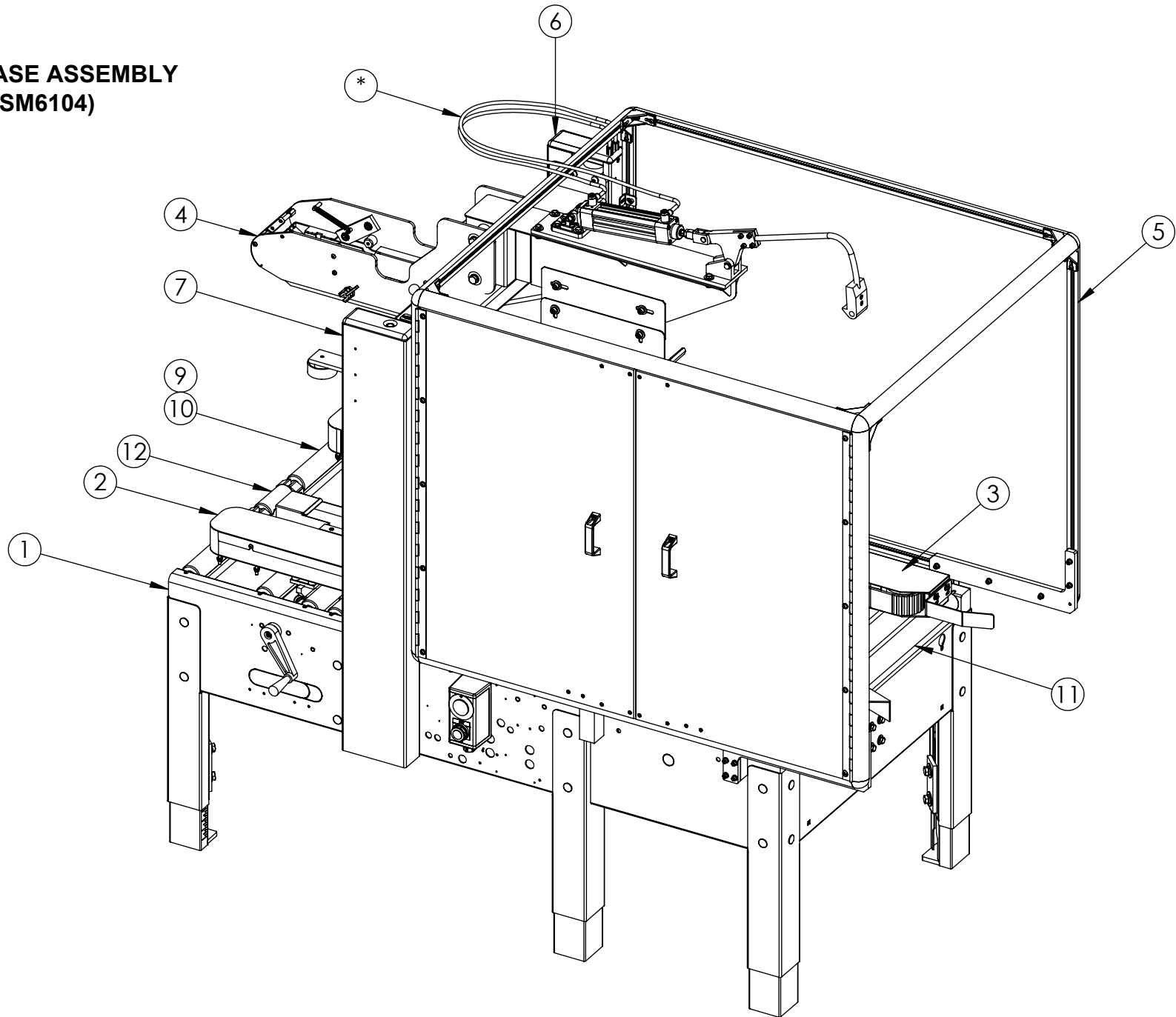



**BASE ASSEMBLY  
(USM6104)**

ITEM NO.	PART NUMBER	DESCRIPTION	QTY.
1	USM7086	SS BASE ASSEMBLY	1
2	USM7081	SS DRIVE SECTION ASS'Y LH	1
3	USM7082	SS DRIVE SECTION ASS'Y RH	1
4	USM7079	SS BRIDGE WITH SUB ASSEMBLIES	1
5	USM7076	UA CENTER DOORS GUARDING	1
6	USM7083	SS COLUMN ASSEMBLY RH	1
7	USM7084	SS COLUMN ASSEMBLY LH	1
8	USM7080	SS PNEUMATIC ASSEMBLY	1
9	UPM3300	SS FASTENER FOR 1.9 OD ROLL BLIND HOLE	68
10	UPM3301	ROLLER	26
11	UPM4139	ROLLER	7
12	UPM3320	ROLLER	1

**BASE ASSEMBLY  
(USM6104)**

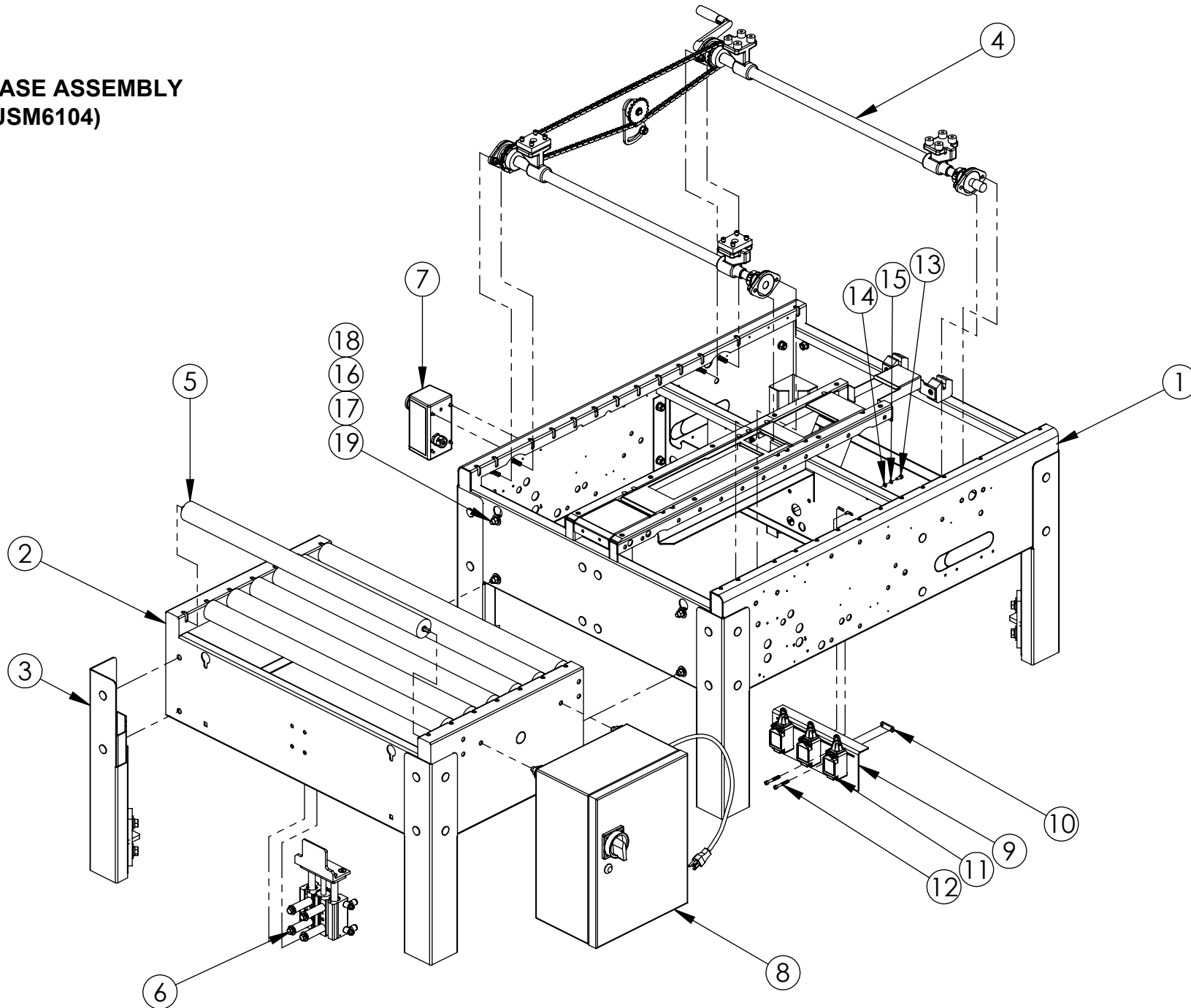

**BASE ASSEMBLY  
(USM6104)**

ITEM NO.	PART NUMBER	DESCRIPTION	QTY.
1	UAM0352	BASE SUB-ASS'Y	1
2	UPM4154EV	INFEED TABLE	1
3	UAM0275	LEG ASSEMBLY METRIC	6
4	USM6111	DRIVE CENTRING ASS'Y	1
5	UPM4173	PVC ROL CHARCOAL DIA 1.9 X 31.04	7
6	USM6110	GATE SA BOSCH GUIDED CYLINDER	1
7	UAM1084	STOP START ELECTR. BOX	1
8	USM0808	ELECTRIC ASSEMBLY	1
9	UPM4402EV	LIMIT SWITCH SUPPORT	1
10	UPM4424	Omron Switch Double Nut	3
11	UPM4403EV	Omron WLD2-TS Limit Switch	3
12	UF4304	SHCS M5 x 0.8 x 40mm	6
13	UF9154	SHCS M5-0.8 X 12	4
14	UF1827	FW M5	4
15	UF7023	LW 5MM	4
16	UF1770	L.W. ZINC 3/8	4
17	UF1540	HNR 3/8-16	4
18	UF1720	REG F.W. ZINC 3/8	4
19	UF4020	CARRIAGE BOLT 3/8-16 X 1	4

**BASE SUB-ASSEMBLY  
(UAM0352)**

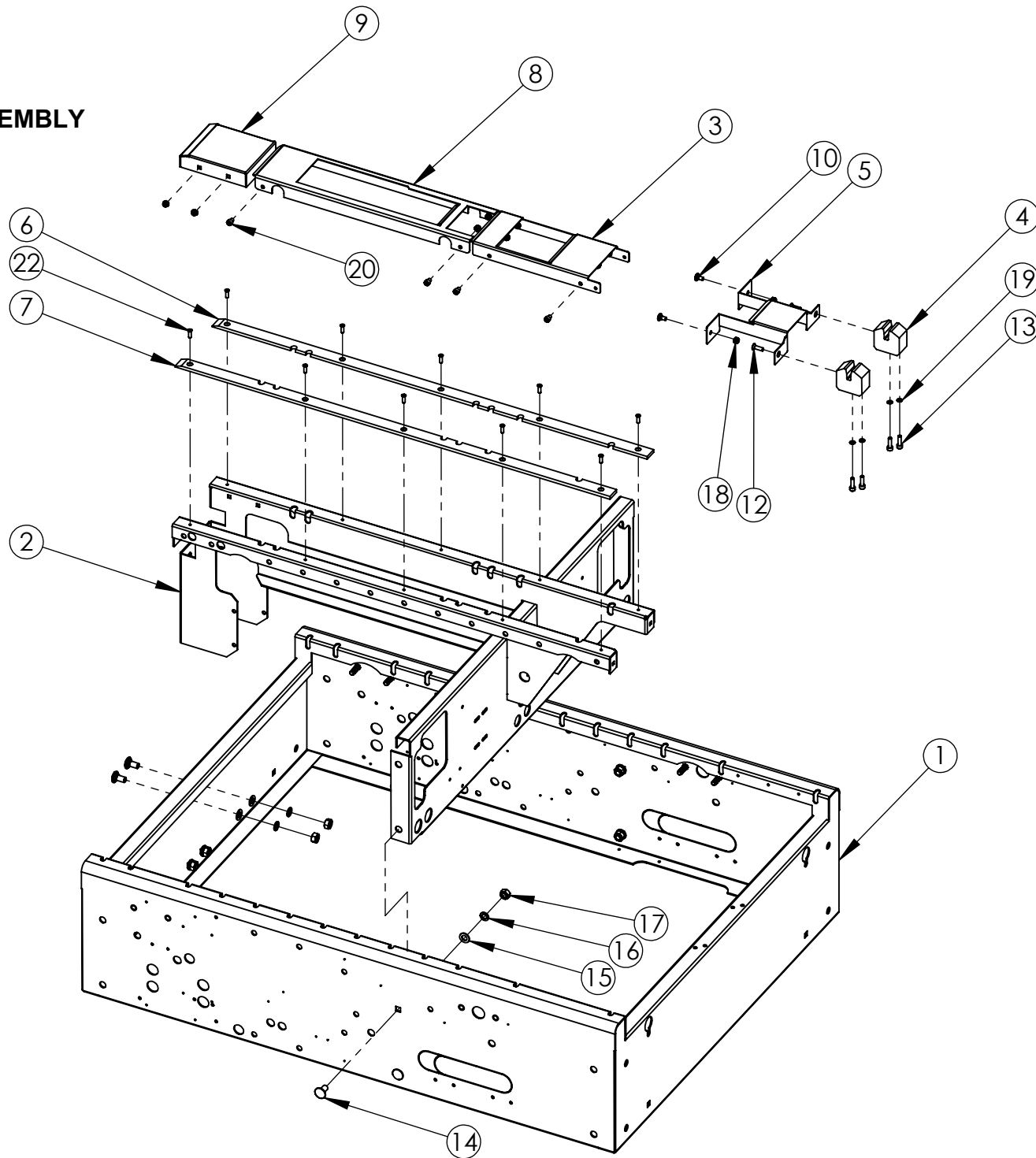

**BASE SUB-ASSEMBLY  
(UAM0352)**

ITEM NO.	PART NUMBER	DESCRIPTION	QTY.
1	UPM3287EV	OUTSIDE FRAME	1
2	UPM2522EV	TRANSVERSE BRACING	1
3	UPM3553	NEAR GAP FILLER UA2000	1
4	UPM3234EV	OUTLET ROLLER BLOCK	2
5	UPM3551EV	OUTLET COVER	1
6	UPM0609EV	SLIDING PAD L.H.	1
7	UPM0606EV	SLIDING PAD R.H.	1
8	UPM3235	ET T. H. INSERT 2" (OPTION)	1
9	UPM3229	INLET COVER	1
10	UF3713	CARRIAGE BOLT M6-1 x 12mm	5
12	UF5402	FHCS M6 - 1 x 20	2
13	UF0835	SHCS M6-1 X 20mm	4
14	UF4229	CARRIAGE BOLT M10-1.5 x 20	8
15	UF3680	FW M10	8
16	UF6371	LW M10	8
17	UF6314	HNR M10 x 1.5	8
18	UF5900	NYLON LOCK NUT M6-1.0	14
19	UF6363	LW M6	4
20	UF0810	SHCS M6-1 x 8	8
21	UF3745	SS CARRIAGE BOLT M6-1 x 12mm	1
22	UF4114	SELF TAPPING SCREW M5 x 16mm	10

# BASE ASSEMBLY (USM6104) MECHANISM

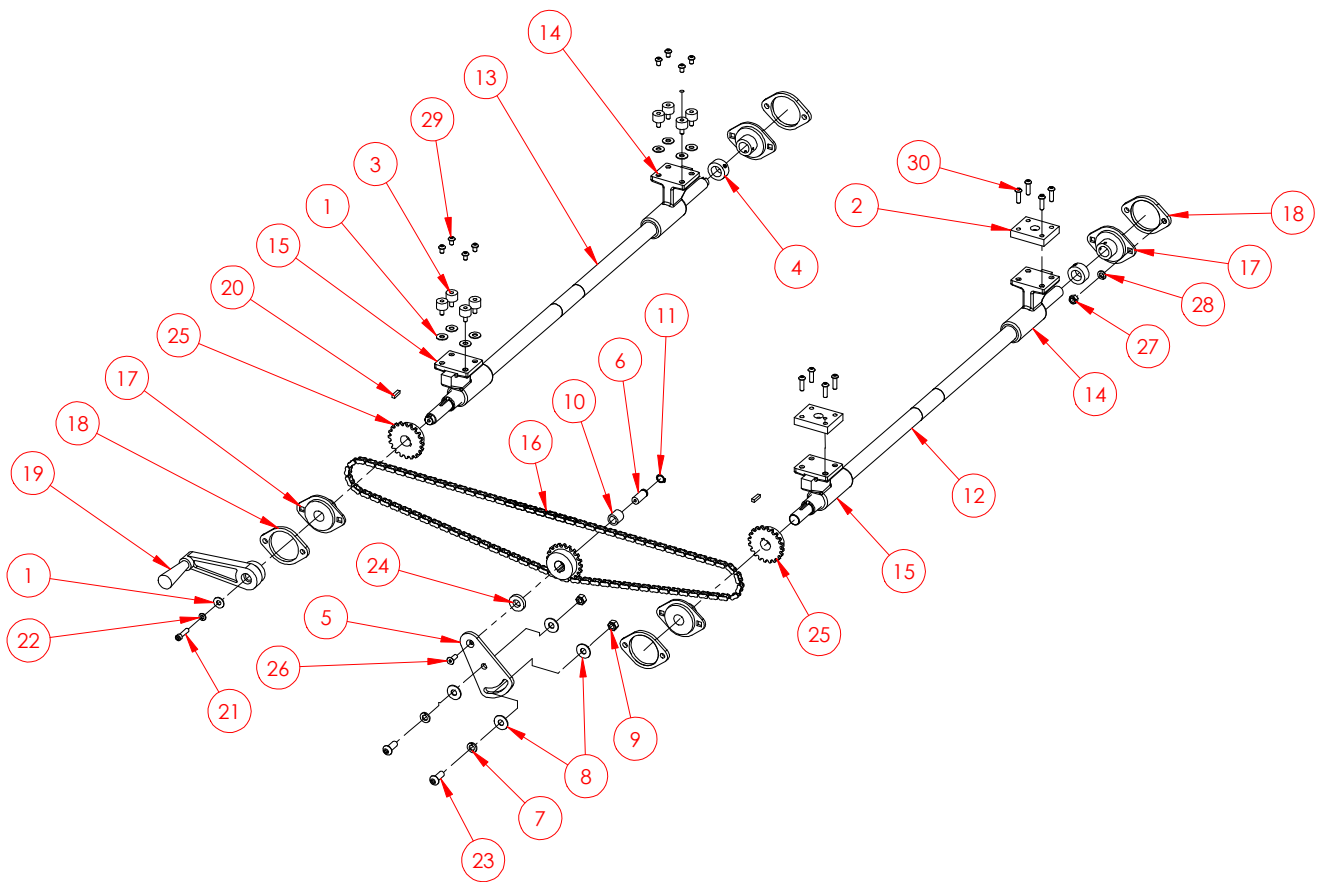

**BASE ASSEMBLY  
(USM6104)  
MECHANISM**

ITEM	PART #	DESCRIPTION	QTY.
1	UF1700	FW 1/4 ZINC	8
2	UPM3242EV	DRIVE SUPPORT SPACER	2
3	UPM0576	BUMPER	8
4	UF2231	SHAFT COLLAR W/SET SC-3/4" BORE	2
5	UPM0631EV	CHAIN TENSIONNER , BASE PLATE	1
6	UPM0640EV	CHAIN TENSIONNER , PIN	1
7	UF6371	L.W. M10	2
8	UF3680	REG F.W. M10	4
9	UF6314	HNR M10-1.5	2
10	UPM0639	SLEEVE BEARING 1/2ID 3/4OD 3/4LG	1
11	UF6300	RET'G RING EXT 12MM	1
12	UPM0573EV	ACME SHAFT, NO HANDLE	1
13	UPM0566EV	ACME SHAFT, FOR HANDLE	1
14	UPM0574EV	CASTING_MACH'D_1.0_SQUARE_RH	2
15	UPM0575EV	CASTING_MACH'D_1.0_SQUARE_LH	2
16	UPM0691	CHAIN 35 FOR USA 2024 SB2	1
17	UPM0523	FLANGE BEARING .75" DIA	4
18	UPM2198EV	BEARING SPACER	4
19	UPE0001EV	CRANK HANDLE	1
20	UF2210EV	SQUARE KEY ROUND END 5 X 5 X 20	2
21	UF0840	SHCS HK M6-1.0 X 25MM	1
22	UF6363	L.W. ZINC M6	1
23	UF6382	HHCS HK M10-1.5 X 25MM	2
24	UPM0641EV	CHAIN TENSIONNER SPACER	1
25	UPM0620EV	SPROCKET 35B20.75ID C/W 5MM KW	3
26	UF1192	FHCS HK M6-1.0 X 16MM	1
27	UF0866	HNR M8	2
28	UF0867	L.W. ZINC M8	2
29	UF1230	BHCS 1/4-20 X 3/8	8
30	UF1263	BHCS HK 1/4-20 X 1 1/4"	8
31	UF1828	FW M6	1

# LEG ASSEMBLY (UAM0275)

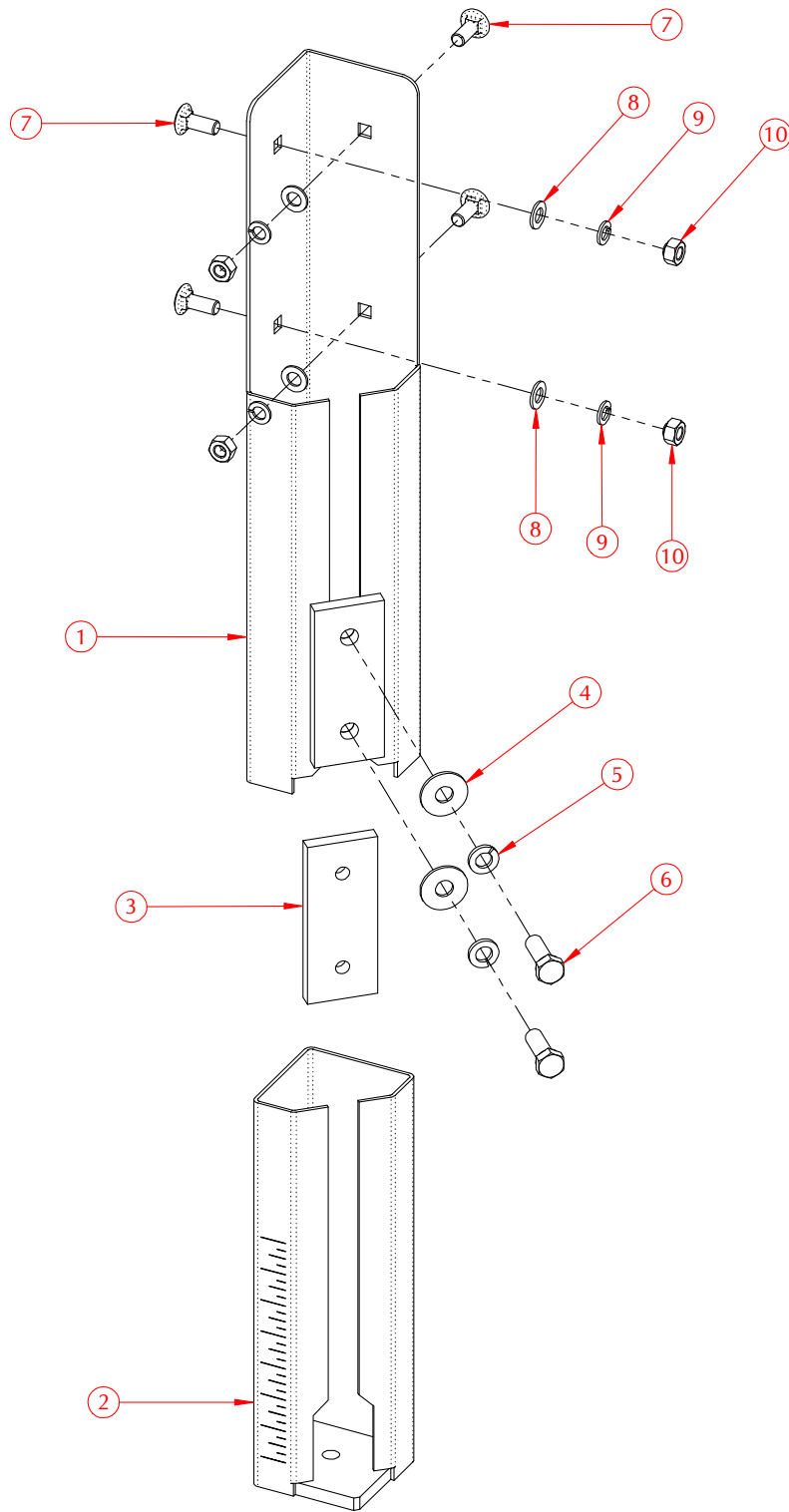



# LEG ASSEMBLY (UAM0275)

ITEM	PART #	DESCRIPTION	QTY.
1	UPM7640	LEG WELDMENT	1
2	UPM7641	LEG ADJUSTMENT	1
3	UPM7642	LEG FRICTION PLATE	1
4	UF4231	FW M12	2
5	UF4230	L.W. ZINC M12	2
6	UF6393	HHCS M12-1.75 x 35	2
7	UF6392	CARRIAGE BOLT M10-1.5 x 25	4
8	UF3680	FW M10	4
9	UF6371	L.W. M10	4
10	UF6314	HNR M10 x 1.5	4

# GATE ASSEMBLY (USM6110)

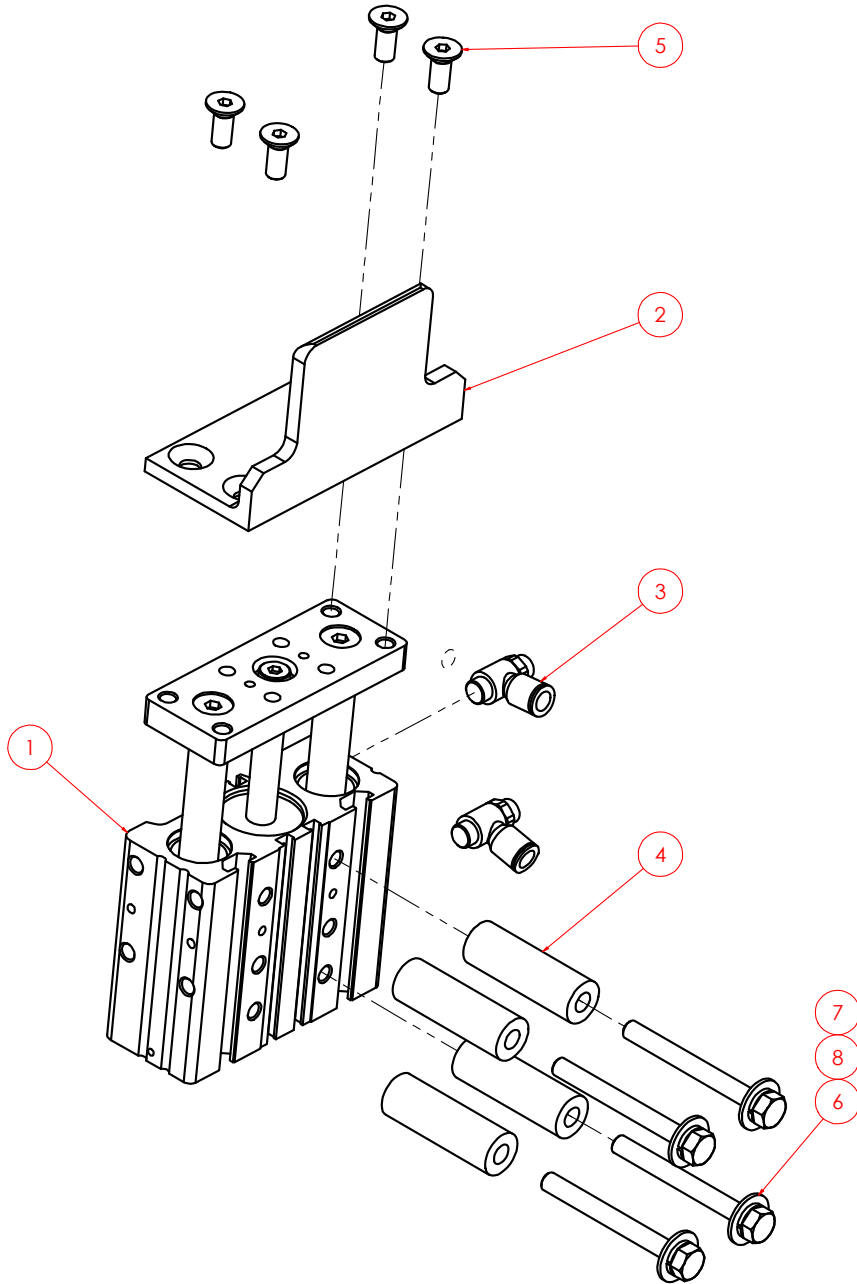

# GATE ASSEMBLY

## USM6110

ITEM NO.	PART NUMBER	DESCRIPTION	QTY.
1	UPM3804	GPC GUIDE CYLINDER 32mm X 50mm	1
2	UPM3854	GATE FOR BOSCH GUIDED CYL	1
3	UPM3787	FLOW CONTROL VALVE G 1/8 male 8mm tube	2
4	UPM3870EV	SPACER 20mm OD X 8.5mm ID X 57.1mm LG	4
5	UF1190	FHCS M8 - 1.25 x 20	4
6	UF1821	FW M8	4
7	UF0867	LW M8	4
8	UF0456	HHCS HK M8 X 75	4

# DRIVE SECTION RIGHT SIDE USM6102

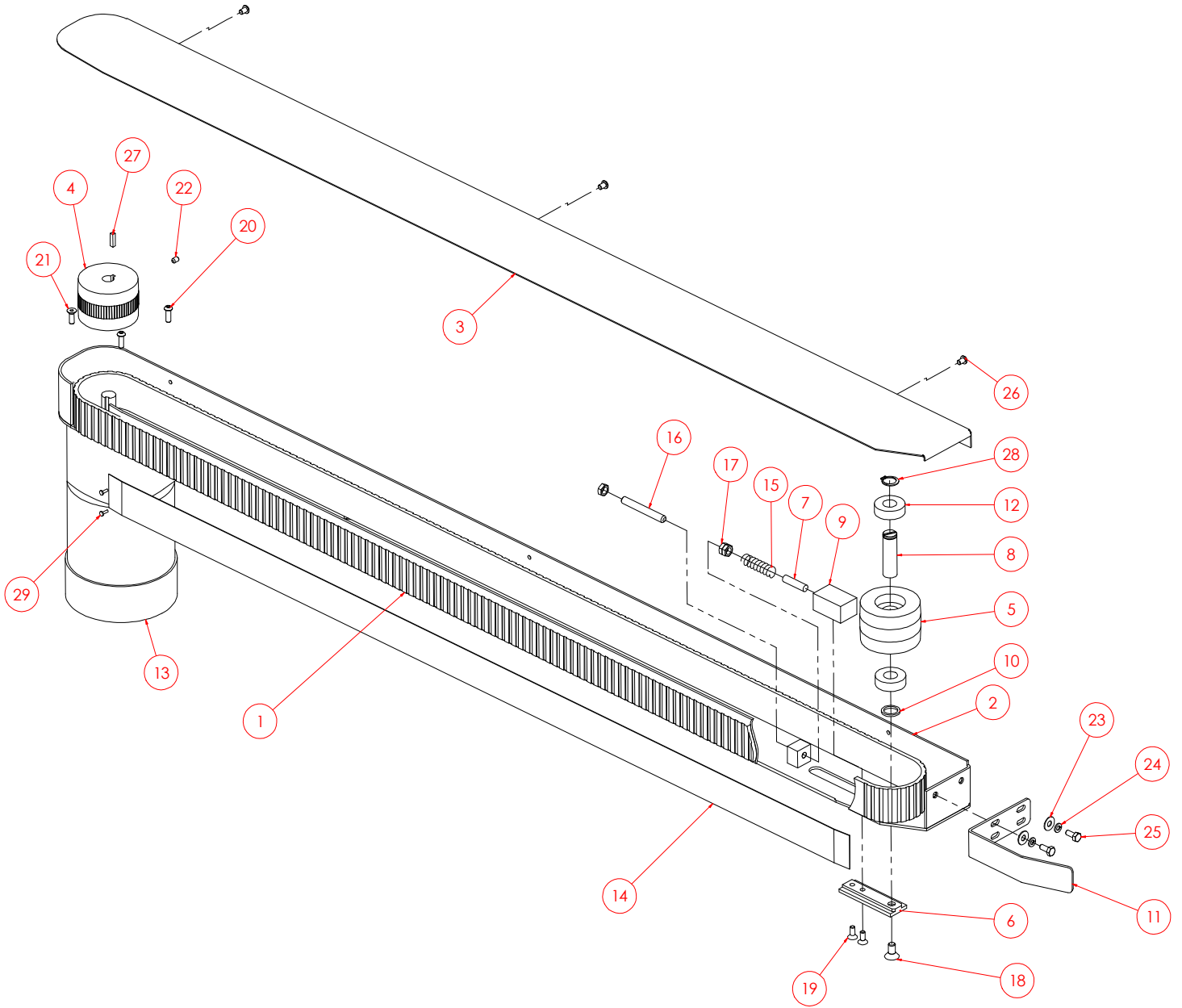

## DRIVE SECTION RIGHT SIDE (USM6102)

ITEM	PART #	DESCRIPTION	QTY.
1	UPM3544	BELT ENDL. SAG 12E, 50mm X 3156mm	1
2	UPM3545EV, _3546EV	DRIVE BASE RIGHT SIDE/ LEFT SIDE	1
3	UPM3547EV, _3548EV	DRIVE BASE COVER RIGHT SIDE / LEFT SIDE	1
4	UPM0129EV	DRIVE PULLEY	1
5	UPM0259EV	IDLER PULLEY	1
6	UPM1879	TENSIONNER SLIDE	1
7	UPM0112	SPRING LOCATOR PIN	1
8	UPM1233EV	IDLER PULLEY SHAFT 50mm	1
9	UPM0101EV	TENSIONNER SPRING HOLDER	1
10	UPM0109	IDLER PULLEY SPACER	1
11	UPM0647EV	CARTON RETAINER	1
12	UPM0324EV	BEARING, PULLEY USA2324	2
13	UPM7116	MOTOR T 1/3 21.4 : 1	1
14	UPM0029	STRIP UHMW 2" X .03"THK	
15	UPM0038	DIE SPRING (DRIVE BASE)	1
16	UF1400	SSS HK 3/8-16 X 3	1
17	UF1540	HNR 3/8-16	3
18	UF6382	FHCS HK M10-1.5 X 25	1
19	UF1192	FHCS HK M6-1 X 16	2
20	UF3711	BHCS M6-1 x 30	3
21	UF3712	FHCS M6 - 1 x 30	1
22	UF6883	SSS M6-1 X 10	1
23	UF1828	FW M6	2
24	UF6363	L.W. ZINC M6	2
25	UF0454	HHCS G5Z M6-1 X 16	2
26	UF1210	BHCS HK M6-1 X 10	3
27	UF2210EV	SQUARE KEY, ZINC 5mm X 5 X 20	1
28	UF2220	EXT RET'G RING 3/4 SHAFT	1
29	UF3691	POP RIVET 4mm	4
30	UF5900	M6 LOCKNUT	4

USM6301

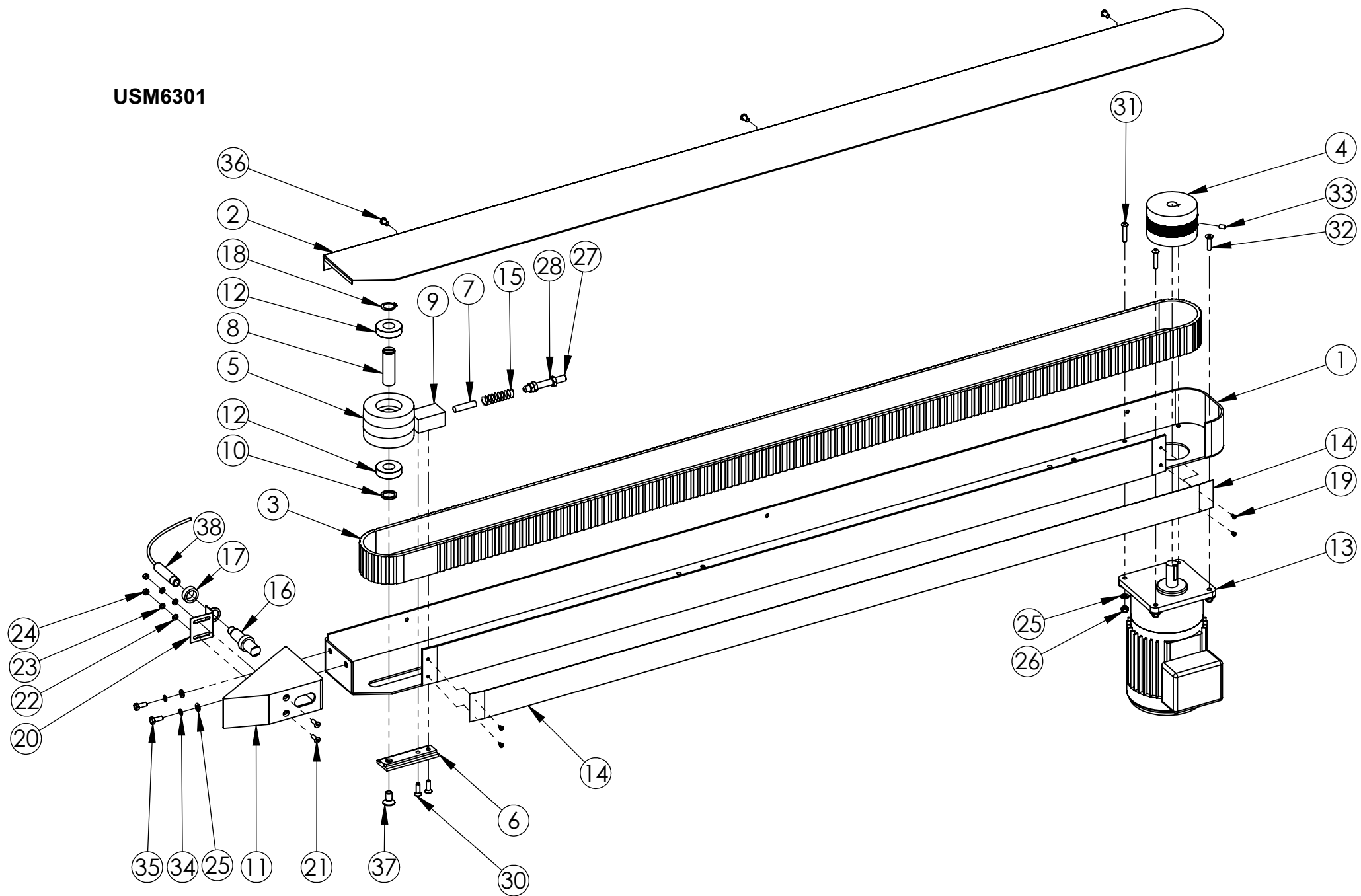

**USM6301**

ITEM	PART #	DESCRIPTION	QTY.
1	UPM3546EV	DRIVE SECTION LH	1
2	UPM3548EV	DRIVE COVER LH	1
3	UPM3544	BELT ENDL. SAG 12E, 2" X 124.5"	1
4	UPM4450	DRIVE PULLEY	1
5	UPM0259	IDLER PULLEY	1
6	UPM1879EV	TENSIONNER SLIDE	1
7	UPM0112	SPRING LOCATOR PIN	1
8	UPM1233EV	IDLER PULLEY SHAFT 50mm	1
9	UPM0101EV	TENSIONNER SPRING HOLDER	1
10	UPM0109	IDLER PULLEY SPACER	1
11	UPM3574EV	CARTON RETAINER	1
12	UPM0324	BEARING, PULLEY	2
13	UPM7116	MOTOR T 1/3 21.4 : 1	1
14	UPM0029	STRIP UHMW 2" X .03"THK	1
15	UPM0038	DIE SPRING (DRIVE BASE)	1
16	UPM0317	PHOTOELECTRIC SENSOR	1
17	UPM0317	PHOTOELECTRIC SENSOR NUT	1
18	UF2220	EXT RET'G RING 3/4" SHAFT	1
19	UF2080	POP RIVET S-44	4

ITEM	PART #	DESCRIPTION	QTY.
20	UPM3248EV	SENSOR SUPPORT	1
21	UF5404	FHCS M5 - 0.8 x 16 mm	2
22	UF1827	FW M5	2
23	UF7023	LW 5MM	2
24	UF6307	HEX NUT M5-0.8	2
25	UF1828	FW M6	6
26	UF5900	NYLON LOCK NUT M6-1.0	4
27	UF1400	SSS HK 3/8-16 X 3	1
28	UF1610	HNJ 3/8-16	3
30	UF5402	FHCS M6 - 1 x 20	2
31	UF3711	BHCS M6-1 x 30mm	3
32	UF1194	FHCS M6 - 1 x 25 mm	1
33	UF3683	SSS M6 X 10mm	2
34	UF6363	LW M6	2
35	UF0454	HHCS M6-1.0 X 16mm	2
36	UF1195	BHCS M6-1 x 12 mm	3
37	UF6397	FHCS M10-1.5 x 20mm	1
38	X2094	Quick Connect Yellow Cable "L"	1

USM6100

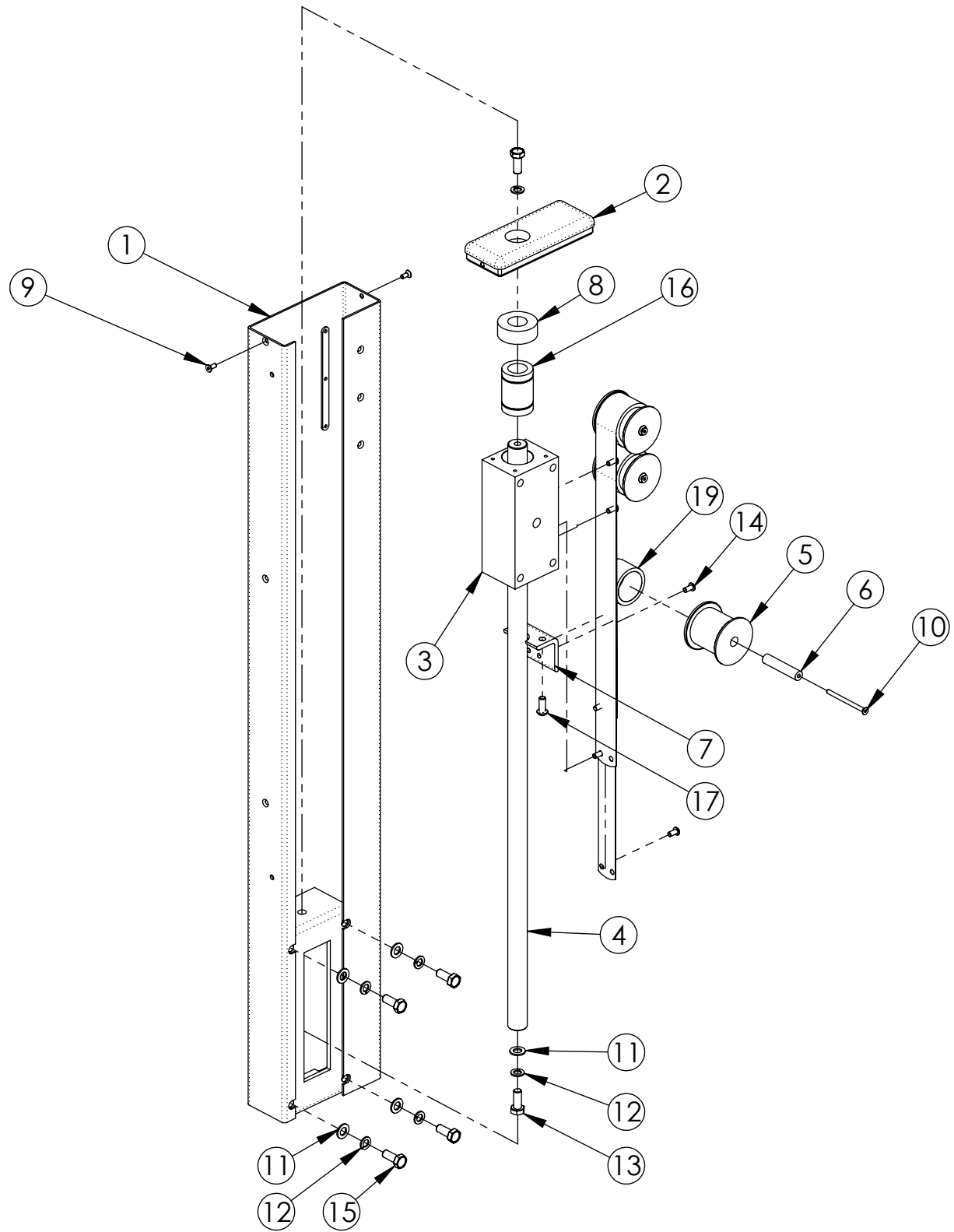



**USM6100**

ITEM NO.	PART NUMBER	DESCRIPTION	QTY.
1	UPM4428EV	COLUMN LH	1
2	UPM0741EV	COLUMN CAP LEFT SIDE	1
3	UPM0737EV	COLUMN BLOCK LEFT SIDE	1
4	UPM0738EV	COLUMN SHAFT	1
5	UPM0742	SPRING SPOOL	3
6	UPM0743	SPRING MANDREL SHAFT	3
7	UPM3730EV	SPRING ANCHOR LEFT SIDE	1
8	UPM2251	SAFETY BUMPER	1
9	UF5400	FHCS M5-0.8 x 12 mm	2
10	UF1157	FHCS M5-0.8 x 70	3
11	UF3680	FW M10	5
12	UF6371	LW M10	6
13	UF6382	HHCS M10-1.5 x 25 mm	2
14	UF1195	BHCS M6-1 x 12 mm	6
15	UF3647	HHCS M10-1.25 x 25 mm	4
16	UPM4986	LINEAR BEARING 25 mm	2
17	UF1318	BHCS M8-1.25 x 20mm	2
18	UPM2181	CONSTANT FORCE SPRING	2
19	UPM0328	CONSTANT FORCE SPRING	1

USM6101

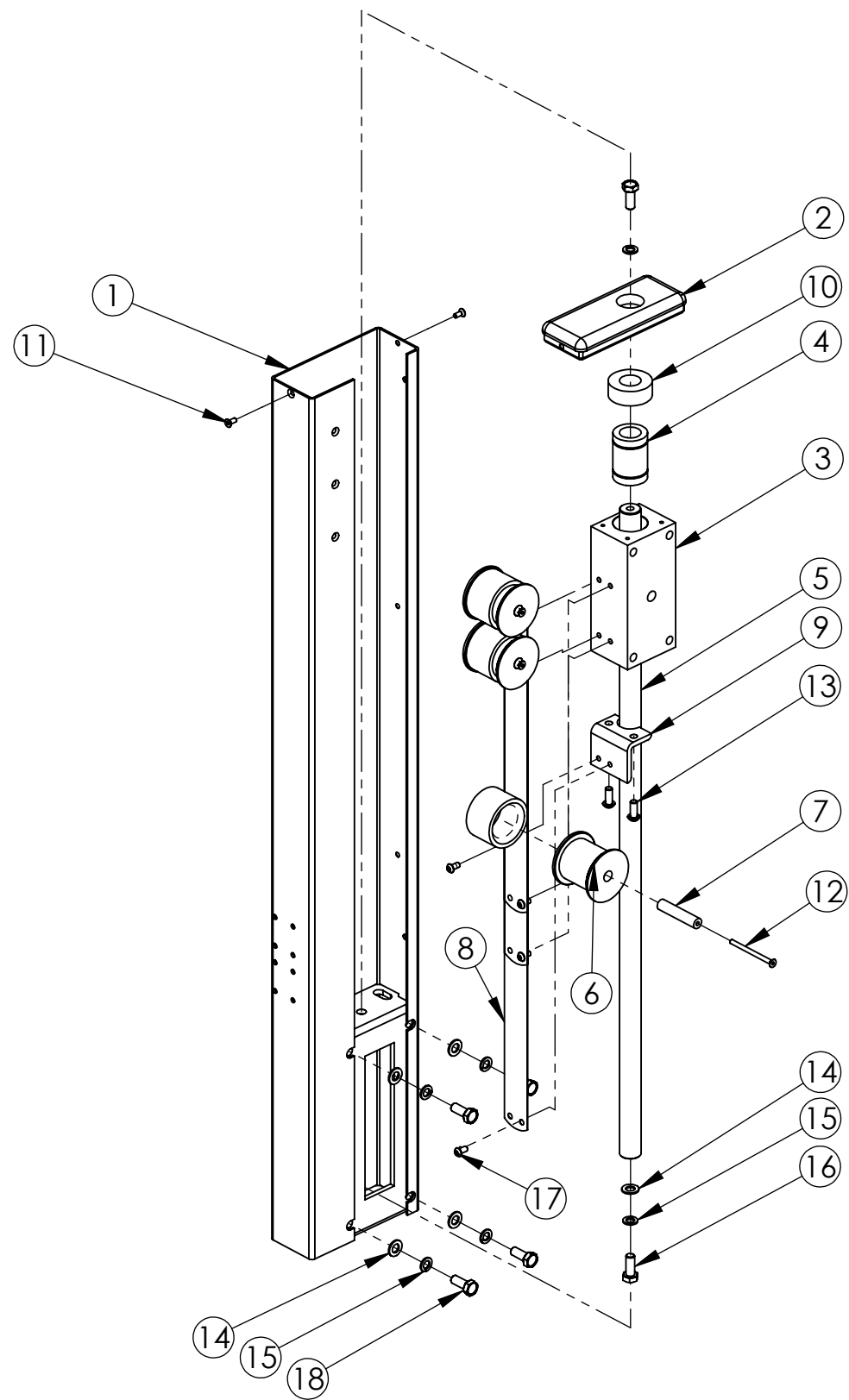

**USM6101**

ITEM	PART #	DESCRIPTION	QTY.
1	UPM4429EV	COLUMN RH	1
2	UPM2182EV	COLUMN CAP RIGHT SIDE	1
3	UPM0735EV	COLUMN BLOCK, RIGHT	1
4	UPM4986	LINEAR BEARING 25 mm	2
5	UPM0738EV	COLUMN SHAFT	1
6	UPM0742	SPRING SPOOL	3
7	UPM0743	SPRING MANDREL SHAFT	3
8	UPM2181	CONSTANT FORCE SPRING	3
9	UPM3731EV	SPRING ANCHOR RIGHT SIDE	1
10	UPM2251	SAFETY BUMPER	1
11	UF5400	FHCS M5-0.8 x 12 mm	2
12	UF1157	FHCS M5-0.8 x 70	3
13	UF1318	M8-1.25 x 20 BHCS	2
14	UF3680	FW M10	5
15	UF6371	LW M10	6
16	UF6382	HHCS M10-1.5 x 25 mm	2
17	UF1195	BHCS M6-1 x 12 mm	6
18	UF3647	HHCS M10-1.25 x 25 mm	4

# FLOATING TAPE HEAD BOX ASSEMBLY (USM6105)

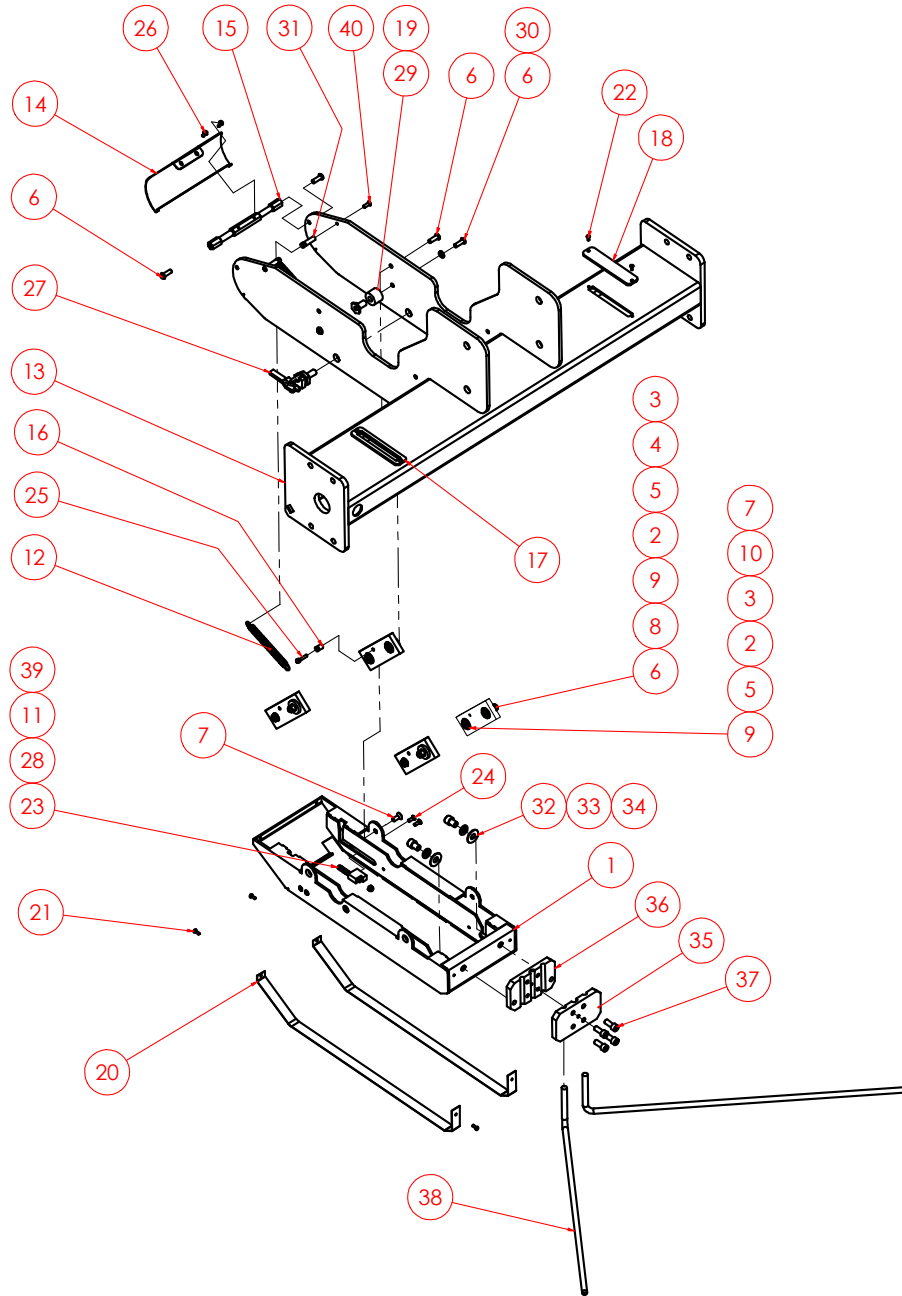

# FLOATING TAPE HEAD BOX ASSEMBLY (USM6105)

ITEM NO.	PART NUMBER	DESCRIPTION	QTY.
1	UPM3550EV	T.H.BOX	1
2	UPM1783EV	PIVOT PLATE FRONT	4
3	UPH0089EV	BEARING PERMAGLIDE D1210	8
4	UPM0968EV	PIVOT SHAFT T.H. BOX 222	4
5	UF6300	12mm RETAINING RING	8
6	UF1250EV	BHCS M6-1.0 X 16	8
7	UF1192	FHCS HK M6-1.0 X 16	4
8	UPM1158	PIVOT SHAFT SPACER	4
9	UF1940	F.W. NYLON 1/2IDx.772ODx.032TH	16
10	UPM2247EV	PIVOT SHAFT SHORT T.H. BOX 222	4
11	UPM1123EV	SPRING SUPPORT	2
12	UPM1042	PIVOT EXTENTION SPRING	2
13	UPM3549EV	BRIDGE, WELDMENT	1
14	UPM3292EV	REAR COVER GUARDING	1
15	UPM3291EV	HEXAGON SPACER BAR , REAR	1
16	UPM0962EV	SPRING RETAINER SHORT	2
17	UPM1011	BRIDGE PLATE COVER SLOTTED	1
18	UPM1008	BRIDGE PLATE COVER	1
19	UPM2168EV	STOP RETAINER T.H. BOX	2
20	UPM0029	STRIP, UHMW, 2" W X .03" THK	2
21	UF3691	POP RIVET 4mm	4
22	UPM2192	BLACK BELLY BUTTON	4
23	UF6375	SHCS HK M4-0.7 X 50	2
24	UF0902EV	FHCS M4-0.7 X 12	4
25	UF3646	SHCS HK M4-0.7 X 20	2
26	UF3649	BHCS M4-0.7 X 12	4
27	UPM2196	TOGGLE CLAMP	1
28	UPM1068	COMP.SPRING SWIVEL T.H. ASSY	2
29	UPM4449	FLOATING THB STOP	6
30	UF6363	L.W. ZINC M6	2
31	UPM0967EV	SPRING RETAINER LONG	2
32	UF3680	REG F.W. M10	2
33	UF6371	L.W. ZINC M10	2
34	UF3648	SHCS HK M10-1.5 X 16	2
35	UPM2287EV	PLOW BLOCK FRONT	1
36	UPM7207EV	PLOW BLOCK BACK	1
37	UF0864	SHCS HK M8-1.25 X 20	4
38	UPM3741	PLOW ROD 3FF	2
39	UF6376	NYLON LOCK NUT ZINC M4-0.7	2
40	UF3650	BHCS M4-0.7 X 16	2

# LOCKING MECHANISM (USM0391)

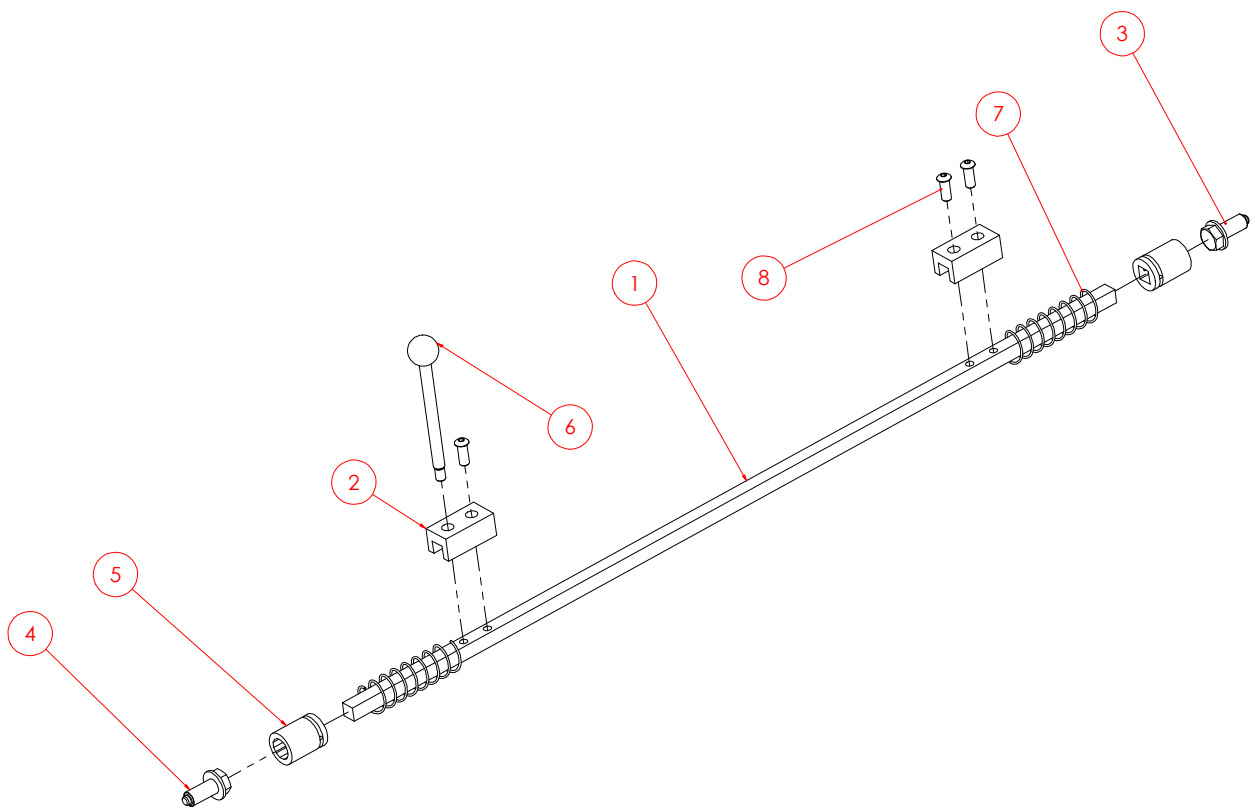

**LOCKING MECANSM  
(USM0391)**

ITEM	PART #	DESCRIPTION	QTY.
1	UPM2187	SQUARE BAR 0.50"	1
2	UPM0700	SINGLE LOCKING BLOCK	2
3	UPM0698	FLANGED SCREW 1/2-13 L.H.	1
4	UPM0699	FLANGED SCREW 1/2-13 R.H.	1
5	UPM0703	SHORT BOX 3/4", 1/2" DR, 12 PT	2
6	UPM0688	SINGLE LOCKING HANDLE	1
7	UPM2184	SPRING, C1100-065-4000-M	2
8	UF1318	BHCS M8-1.25 x 20 mm	3

# COMPRESSION GUIDE (USM6109)

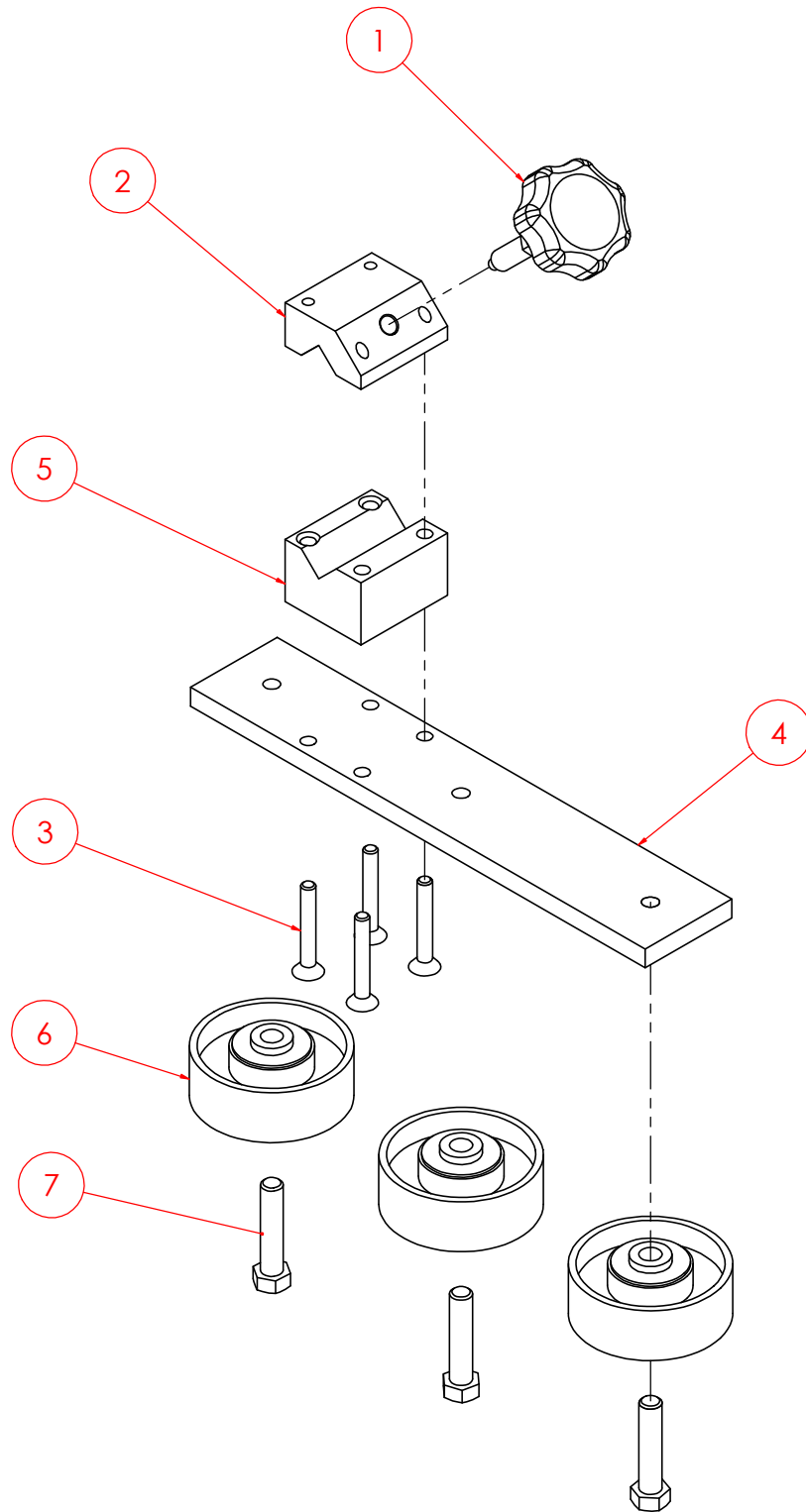



# COMPRESSION GUIDE (USM6109)

ITEM	PART #	DESCRIPTION	QTY.
1	UAM0288	KNOB CW 5mm PIN USA2324	1
2	UPM7538	GUIDE BLOCK TOP	1
3	UF4029	FHCS HK M6-1 X 50	4
4	UPM2173EV	WHEEL SUPPORT PLATE UA METRIC	1
5	UPM3285EV	GUIDE BLOCK	1
6	UPM1659	WHEEL 2-7/8"DIA.COMPR.GUIDE	3
7	UF0240	HHCS 3/8-16 x 1.75	3

**KNOB CW 5mm PIN  
(UAM0288)**

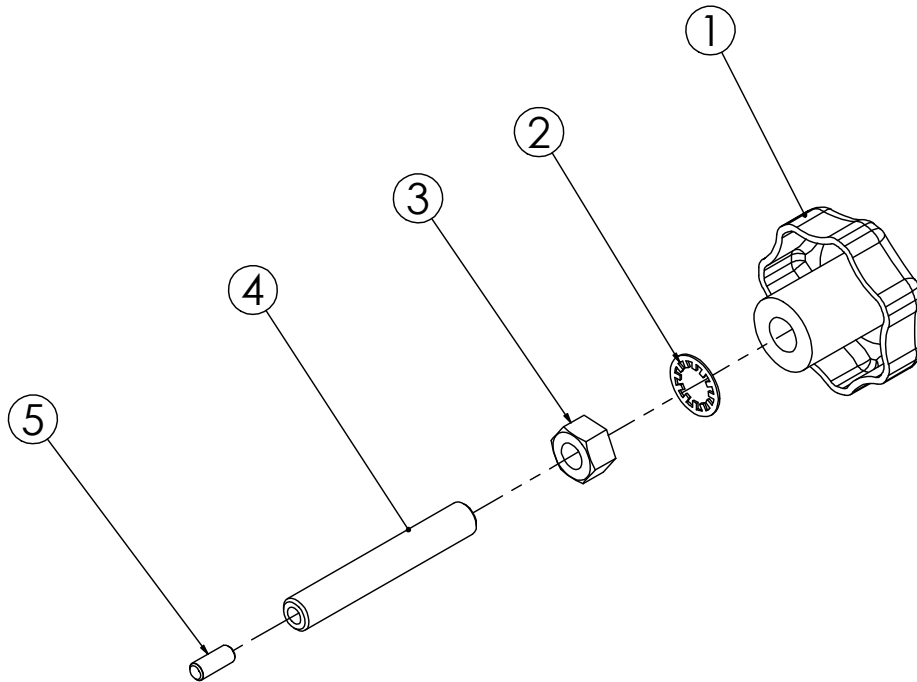

**KNOB CW 5mm PIN  
(UAM0288)**

ITEM	PART #	DESCRIPTION	QTY
1	UPM4506	Knob w 3/8-16unc Hole	1
2	UF9168	Internal Tooth LW 3/8"	1
3	UF1540	HNR 3/8-16	1
4	UF2136EV	Rod Zc 3/8-16 x 2" W/5mm Hole	1
5	UPM0131EV	Brass Pin 5mm	1

# KICKER ASSEMBLY (USM7077)

VERIFY WHICH  
KICKER ASSEMBLY  
BEFORE ORDERING  
SPARE PARTS

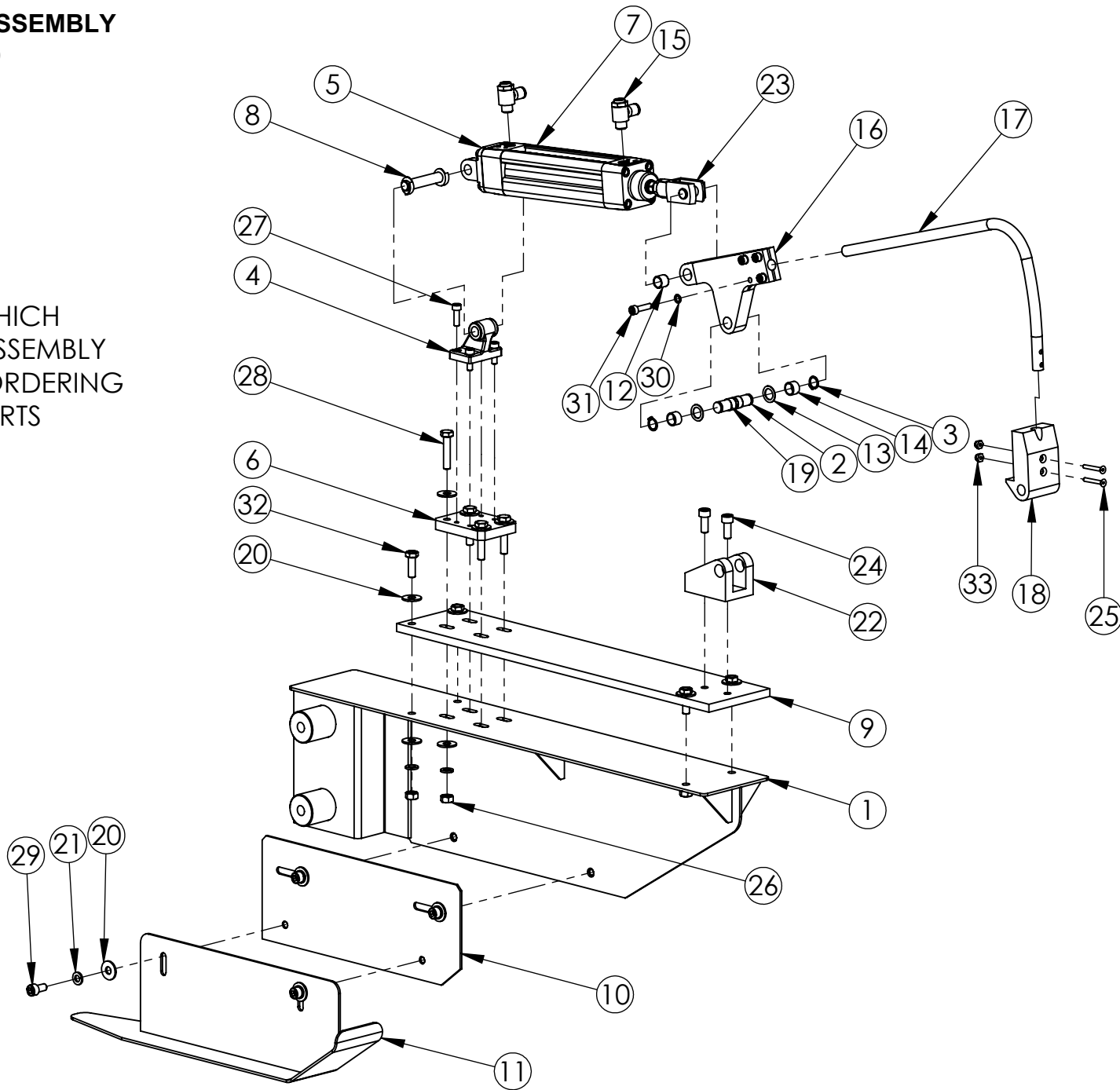

**USM7077**

ITEM NO.	PART NUMBER	DESCRIPTION	QTY.
1	UPM6118	SS BRIDGE EXTENSION	1
2	UPM3849	SS CLEVIS PIN 0.50 DIA	1
3	UF3552	SS 1/2" RETAINING RING	2
4	UPM2900	BEARING BLK FOR 40mmCYL.	1
5	UPM2901	REAR CLEVIS, 40mmCYL.	1
6	UPM2917	CYLINDER ANCHOR BLOCK	1
7	UPM2899	AIR CYL. 40 X 130mm ISO	1
8	UPM6105	SS PIVOT PIN-SNAP RING	1
9	UPM3874EV	KICKER MOUNTING PLATE	1
10	UPM4350EV	SKI MOUNTING PLATE	1
11	UPM4352	SKI	1
12	UPH0907	BEARING 12 x 14 x 12 LG.	1
13	UF1940	F.W. NYLON 1/2IDx.772ODx.032TH	2
14	UPH0089	BEARING GLYCODUR .50 x .38 LG	2
15	UPM3132	FLOW CONTROL G 1/4 MALE X 8mm TUBE	2
16	UPM9693	KICKER BLOCK LIGHT	1
17	UPM2628	UA KICKER TUBE	1
18	UPM2615	UHMW DUCK SHAPE KICKER HEAD	1
19	UPH0909	BEARING 12x14x8LG	2
20	UF3643	SS FW M8	20
21	UF3640	SS LW M8	12
22	UPM6129	SS KICKER CLEVIS	1
23	UPM6128	SS CLEVIS FOR ISO 40mm CYL.	1
24	UF3755	SS SHCS M8-1.25 x 20mm	2
25	UF3775	SS FHCS 8-32 x 1 1/4"	2
26	UF3735	SS HNR M8-1.25	8
27	UF3179	SS SHCS M6-1 x 20mm	4
28	UF3773	SS HHCS M8 - 1.25 x 40mm	4
29	UF3772	SS SHCS M8-1.25 x 16mm	4
30	UF6411	SS LW M6	4
31	UF3180	SS SHCS M6-1 X 25mm	4
32	UF3774	SS HHCS M8-1.25 x 25mm	4
33	UF3388	SS NYLON LOCK NUT #8-32	2



# KICKER ASSEMBLY (USM6107)

ITEM NO.	PART NUMBER	DESCRIPTION	QTY.
1	UPM0380EV	KICKER CLEVIS	1
2	UPM3849EV	SS CLEVIS PIN 12mm	1
3	UF7017	SS 12MM RETAINING RING	2
4	UPM2900	BEARING BLK FOR 40mmCYL.	1
5	UPM2901	REAR CLEVIS, 40mmCYL.	1
6	UPM2917EV	CYLINDER ANCHOR BLOCK	1
7	UF0835	SHCS M6-1 X 20MM	4
8	UPM2899	AIR CYL. 40 X 130mm ISO	1
9	UPM2902	CLEVIS (P1) FOR ISO 40mm CYL.	1
10	UPM2903	PIVOT PIN-SNAP RING	1
11	UPM3874EV	KICKER MOUNTING PLATE	1
12	UPM4350EV	SKI MOUNTING PLATE	1
13	UPM4351EV	BRIDGE EXTENSION	1
14	UPM4352EV	SKI	1
15	UPM0383EV	KICKER UA MINI	1
16	UPM2918EV	KICKER BLOCK, METRIC	1
17	UF4234	HNR ZINC M12-1.75	1
18	UF1821	F.W. ZINC M8	10
19	UF0867	L.W. ZINC M8	10
20	UF5204	SHCS M8-1.25 X 20	2
21	UF6310	HHCS M8-1.25 X 25	2
22	UF4232	HHCS M8-1.25 X 40	4
23	UF0866	HNR M8-1.25	4
24	UPH0907	BEARING 12 x 14 x 12 LG.	1
25	UF1940	F.W. NYLON 1/2IDx.772ODx.032TH	2
26	UF4231	F.W. M12	4
27	UF4230	L.W. M12	4
28	UF3062	HHCS M12-1.75 X 25	4
29	UPH0089EV	BEARING GLYCODUR 12 X 14 X 10	2
30	UPM4451	BEARING 12 X 14 X 18	1

# RIGHT GUARD ASSEMBLY (USM6108)

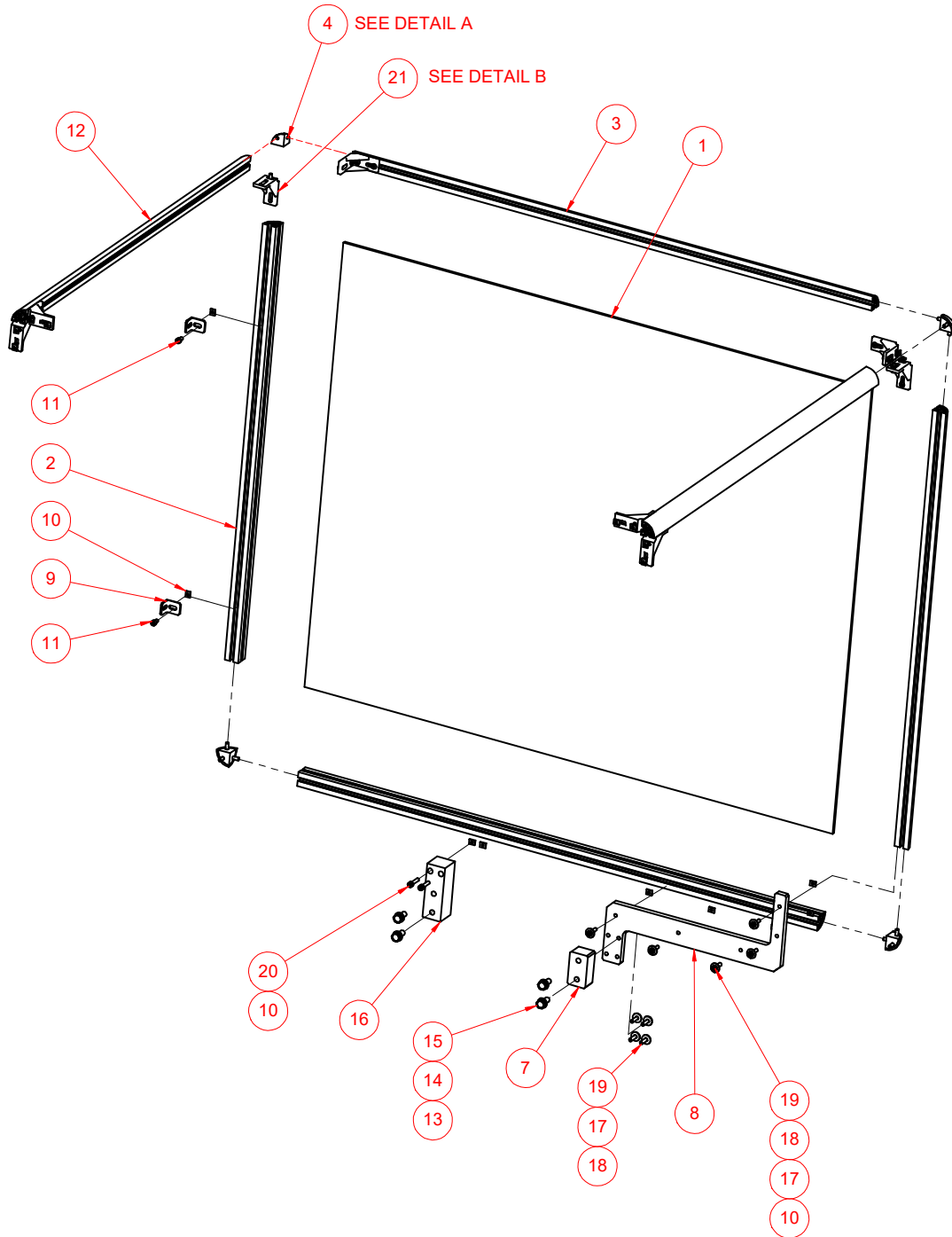



# RIGHT GUARD ASSEMBLY (USM6108)

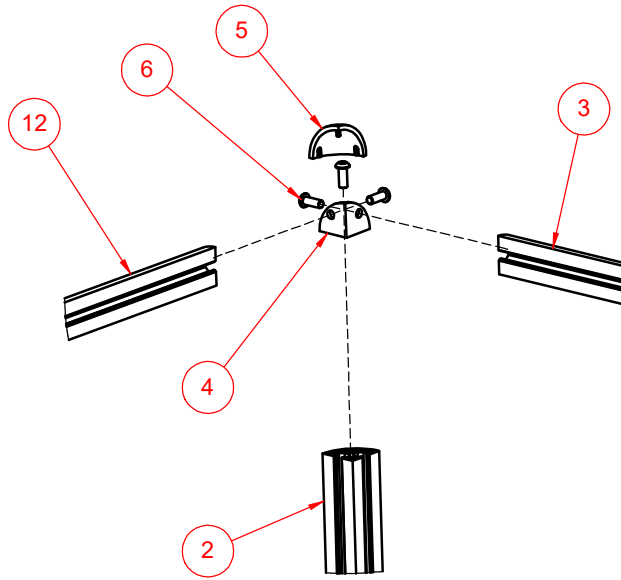

DETAIL A  
CORNERS MOUNTING ARRANGEMENT

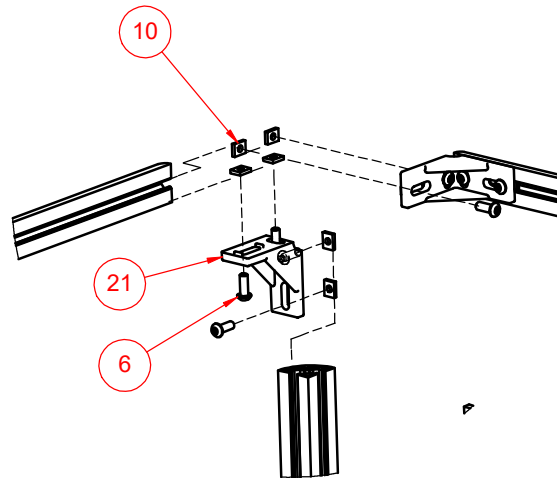

DETAIL B  
INSIDE CORNERS MOUNTING ARRANGEMENT

## RIGHT GUARD ASSEMBLY (USM6108)

ITEM	PART #	DESCRIPTION	QTY.
1	UPM3862EV	LEXAN 6mm X 955mm X 1180mm	1
2	UPM3864EV	VERTICAL EXTRUSION	2
3	UPM3865EV	HORIZONTAL EXTRUSION	2
4	UPM0614EV	CORNER BLOCK	4
5	UPM2922EV	CORNER CAP FINISHING	4
6	UF1250EV	BHCS M6-1 x 16 mm	52
7	UPM3852EV	DOOR SUPPORT MEMBER UA2024 METRIC	1
8	UPM3853EV	DOOR SUPPORT UA 2024 METRIC	1
9	UPM0732EV	UA FIXED GUARDING "L" BRACKET	2
10	UPM0687EV	DROP IN T-NUT M6	41
11	UF0820	SHCS M6-1 x 12	2
12	UPM4512EV	CROSS-OVER EXTRUSION	2
13	UF3680	FW M10	4
14	UF6371	L.W. M10	4
15	UF6382	HHCS M10-1.5 x 25 mm	4
16	UPM4452	2nd SUPPORT MEMBER UA2024 METRIC	1
17	UF1828	REG F.W. M6	9
18	UF6363	LW M6	11
19	UF0840	SHCS M6-1 X 25MM	9
20	UF4236	SHCS M6-1 X 30MM	2
21	UPM4398EV	INSIDE CORNER	8

# OPENED DOOR ASSEMBLY (USM6108)

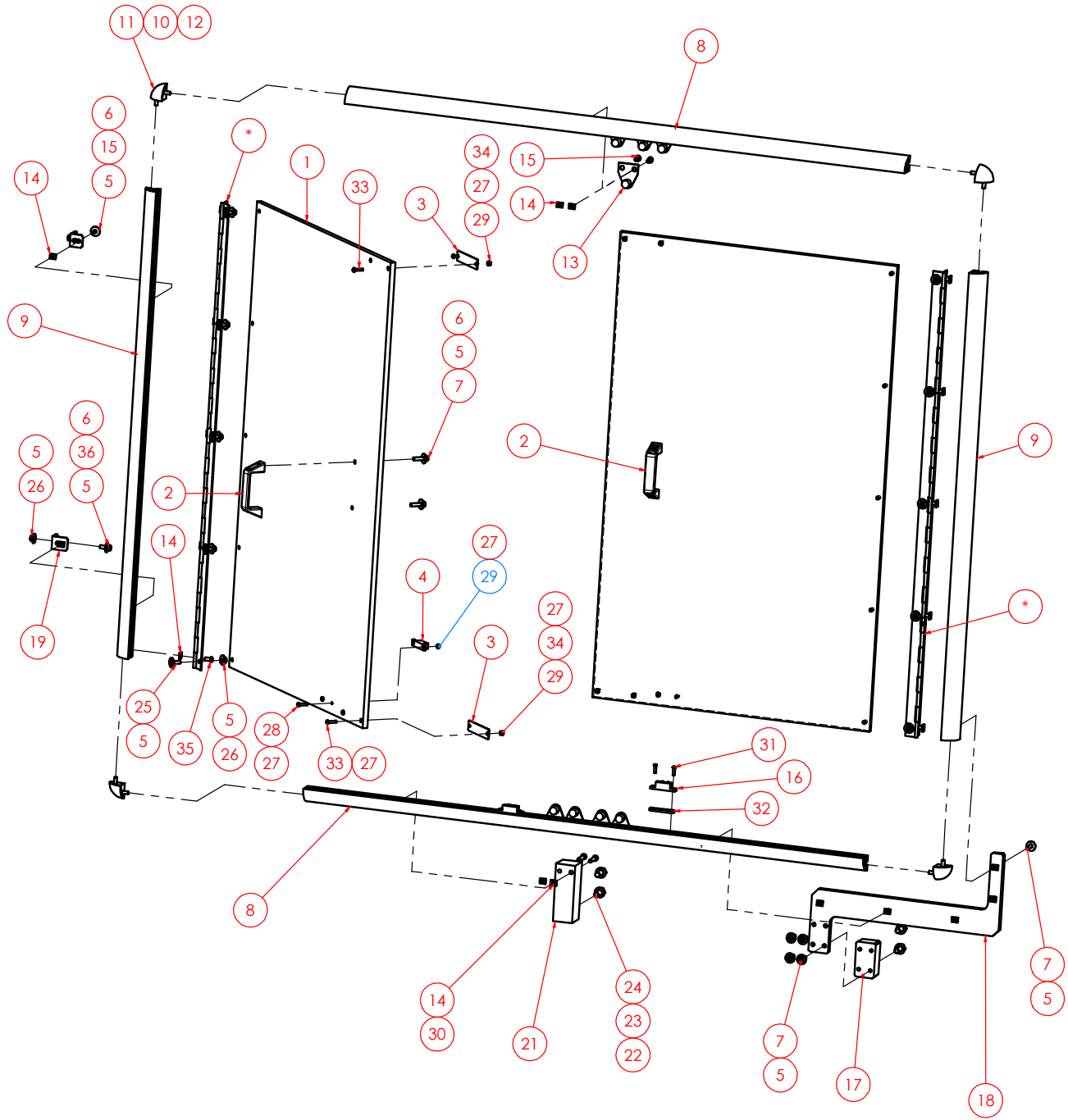

## OPENED DOORS ASSEMBLY (USM6108)

ITEM NO.	PART NUMBER	DESCRIPTION	QTY.
1	UPM3861EV	LEXAN 10.0mm X 575.0mm X 934.0mm	2
2	UPM0794EV	HANDLE	2
3	UPM4400EV	MAGNET PLATE	4
4	UPM4397EV	INTERLOCK, OMRON TYPE GLS-M1	2
5	UF1828	REG F.W. M6	39
6	UF6363	LW M6	16
7	UF0840	SHCS M6-1 X 25MM	13
8	UPM3865EV	HORIZONTAL EXTRUSION	2
9	UPM3864EV	VERTICAL EXTRUSION	2
10	UPM0614EV	CORNER BLOCK	4
11	UPM2922EV	CORNER CAP FINISHING	4
12	UF1250EV	BHCS M6-1 x 16 mm	12
13	UPM4399EV	MAGNET ASSY	8
14	UPM0687EV	DROP IN T-NUT M6	35
15	UF0820	SHCS M6-1 x 12	18
16	UPM4396EV	INTERLOCK, OMRON TYPE GLS-S1	2
17	UPM3852EV	DOOR SUPPORT MEMBER UA2024 METRIC	1
18	UPM3853EV	DOOR SUPPORT UA 2024 METRIC	1
19	UPM0732EV	UA FIXED GUARDING "L" BRACKET	2
20	UPM3857EV	HINGE PIANO 50mm	2
21	UPM4452	2nd SUPPORT MEMBER UA2024 METRIC	1
22	UF3680	FW M10	4
23	UF6371	L.W. M10	4
24	UF6382	HHCS M10-1.5 x 25 mm	4
25	UF1241EV	BHCS M6-1 x 20	10
26	UF5900	NYLON LOCK NUT M6-1.0	13
27	UF3710	FW M4	25
28	UF4238	PHCS M4-0.7 X 20mm	4
29	UF4237	HEX NUT M4-0.7	12
30	UF4236	SHCS M6-1 X 30MM	2
31	UF4239	PHCS M4-0.7 X 15mm	4
32	UPM4453	Omron Interlock Double Nut M4-0.7	2
33	UF4050EV	BHCS M4 - 0.7 x 20	8
34	UF3681	L.W. M4	8
35	UF1195	BHCS M6-1 x 12 mm	10
36	UF0830	SHCS M6-1 x 16 mm	2

# ELECTRIC CONTROLS

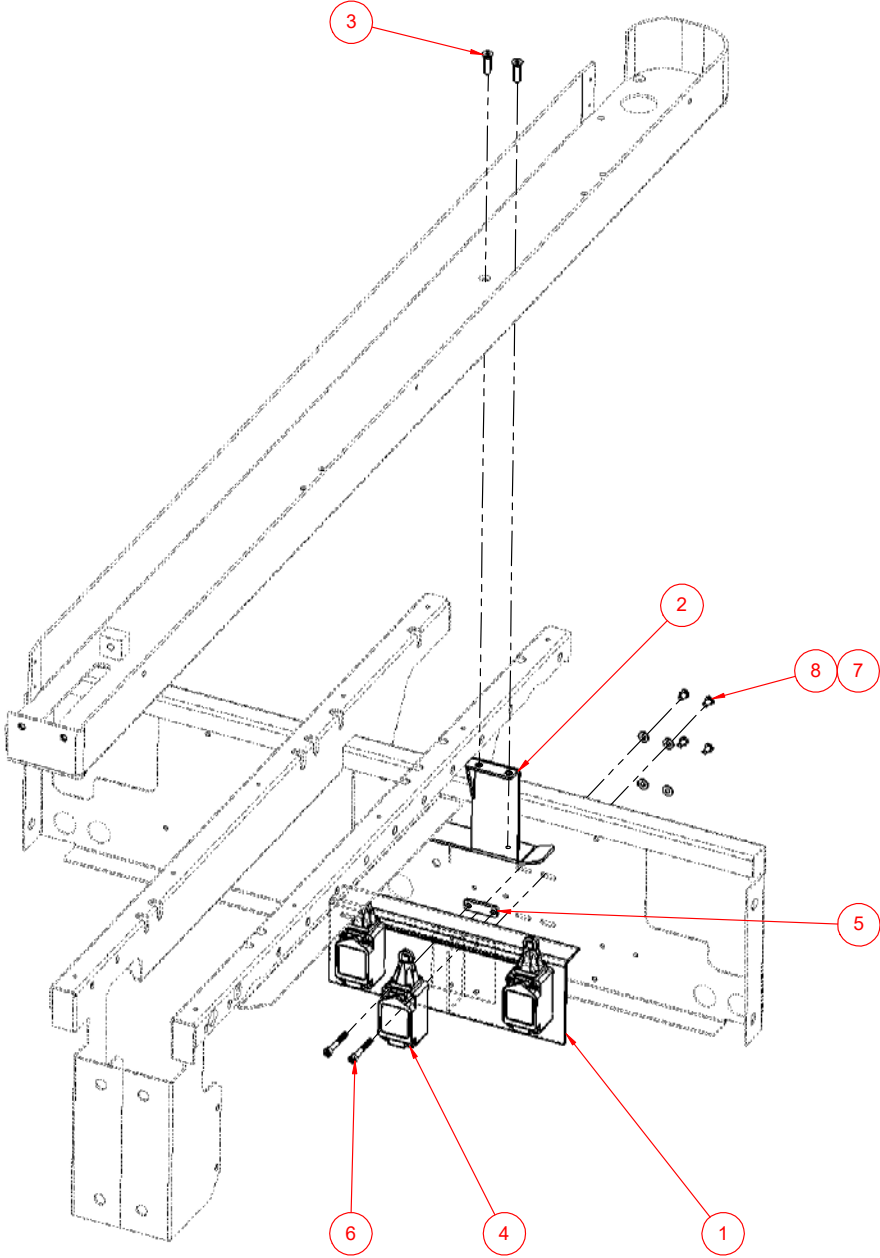

## ELECTRIC CONTROLS

ITEM NO.	PART NUMBER	DESCRIPTION	QTY.
1	UPM4402EV	LIMIT SWITCH SUPPORT	1
2	UPM4401EV	LIMIT SWITCH BRACKET	1
3	UF1194	FHCS M6 - 1 x 25 mm	2
4	UPM4403EV	Omron WLD2-TS Limit Switch	3
5	UPM4424	Omron Switch Double Nut	3
6	UF4304	SHCS M5 x 0.8 x 40MM	6
7	UF1827	FW M5	4
8	UF3686	BHCS M5-0.8 X 10MM	4

# PNEUMATIC (USM6106)

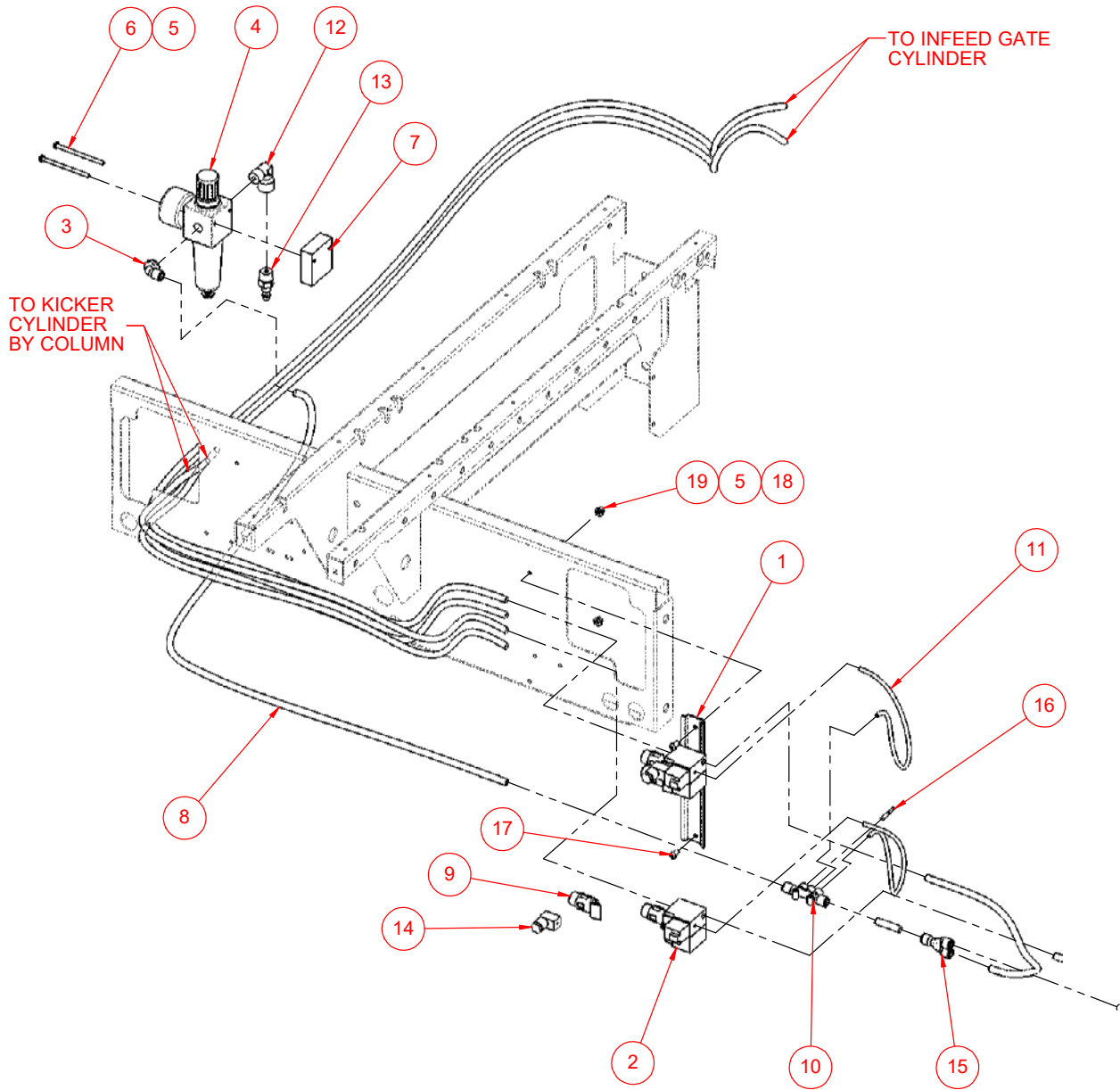

**PNEUMATIC  
(USM6106)**

ITEM	PART #	DESCRIPTION	QTY.
1	UPM0407EV	DIN RAIL	1
2	UPM3394	VALVE 579 5/2 MONOSTABLE 24 VDC	2
3	UPM3179	ELBOW 3/8 MALE x 8mm TUBE	1
4	UPM3267	FILTER REGULATOR NL2 G3/8 0.2 BAR	1
5	UF	L.W. M5	2
6	UF4240	SHCS M5-0.8 X 80 MM	2
7	UPM3755EV	FILTER REG. (UPM3267) MOUNTING BRKT	1
8	UPM3411	TUBING 8mm X 1 BLUE SOFT	8.0 M TOTAL
9	UPM3391	SILENCER 579 VALVE	4
10	UPM3396	MULT T-CON 2 X 8mm TO 3 X 4mm	1
11	UPM3583	PLASTIC TUBE 4mm BLUE	0.8 M TOTAL
12	UPM3175	ELBOW BRSS NKL PLT G3/8M X G3/8F	1
13	UPM0436	FTG Q.D. 3/8 NPT MALE	1
14	UPM3392	ELECT. CONN WITH LED 579 VALVE	2
15	UPM4346	Y connector (8mm to 2 x 8mm)	1
16	UPM4385	PLUG TYPE LB 4 mm TUBE	1
17	UF3687	BHCS M5-0.8 X 12MM	2
18	UF1827	FW M5	2
19	UF6307	HEX NUT M5-0.8	2



# AIR TO COLUMN ASSEMBLY

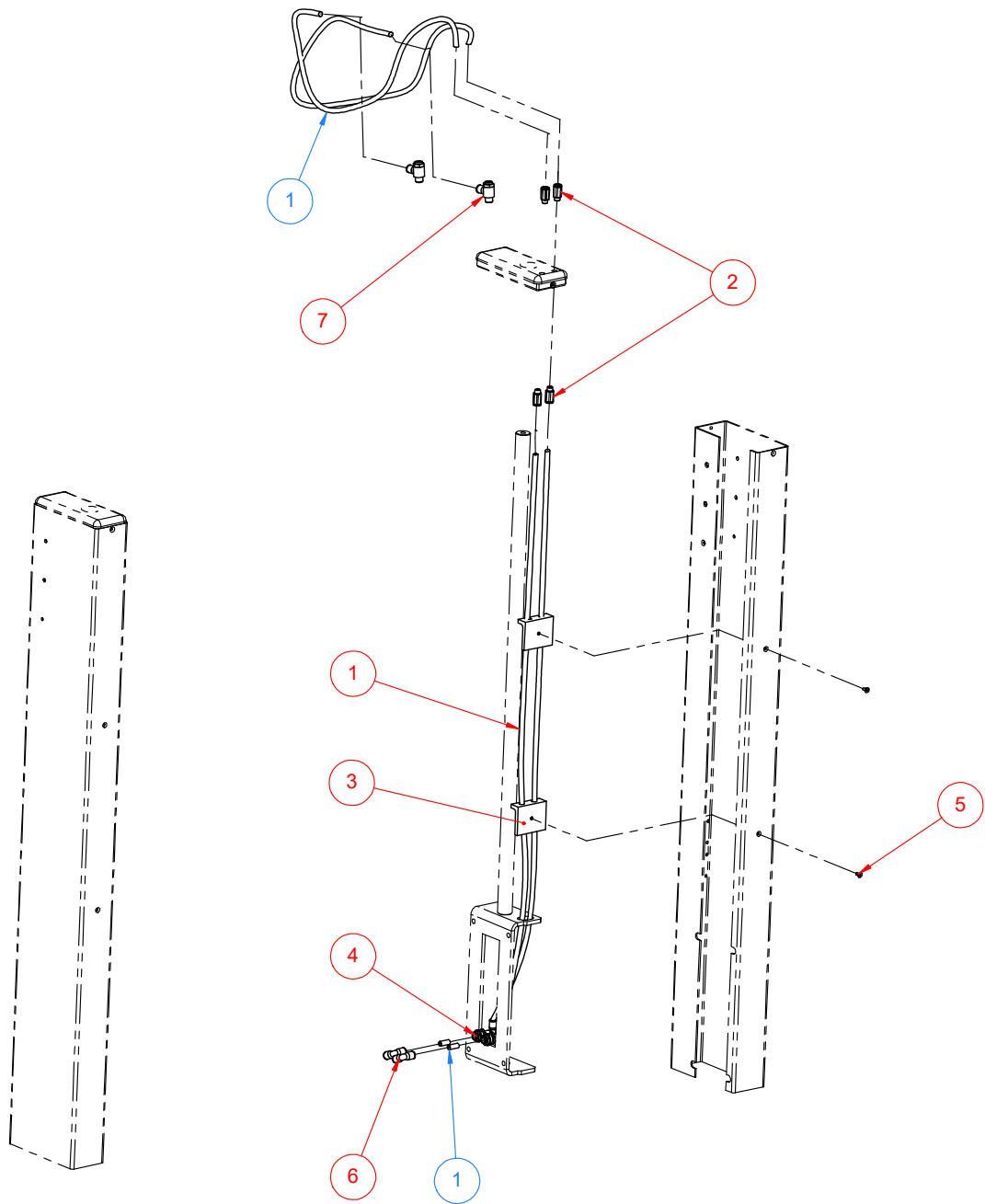

## AIR TO COLUMN ASSEMBLY

ITEM	PART #	DESCRIPTION	QTY.
1	UPM3411	8 mm TUBE	4.0 M TOTAL
2	UPM3182	FTG. STR 8mmTUBE 1/8NPT MALE	4
3	UPM3386EV	AIR TUBE GUIDE	2
4	UPM3336	ELBOW BULKHEAD CONNECTOR 8mm	2
5	UF6305	FHCS M5-0.8 X 10 MM	2
6	UPM3140	FTG "L" 8mm TUBE	2
7	UPM3132	FLOW CONTROL G 1/4 MALE X 8mm TUBE	2

# STOP / START BOX (UAM1084)

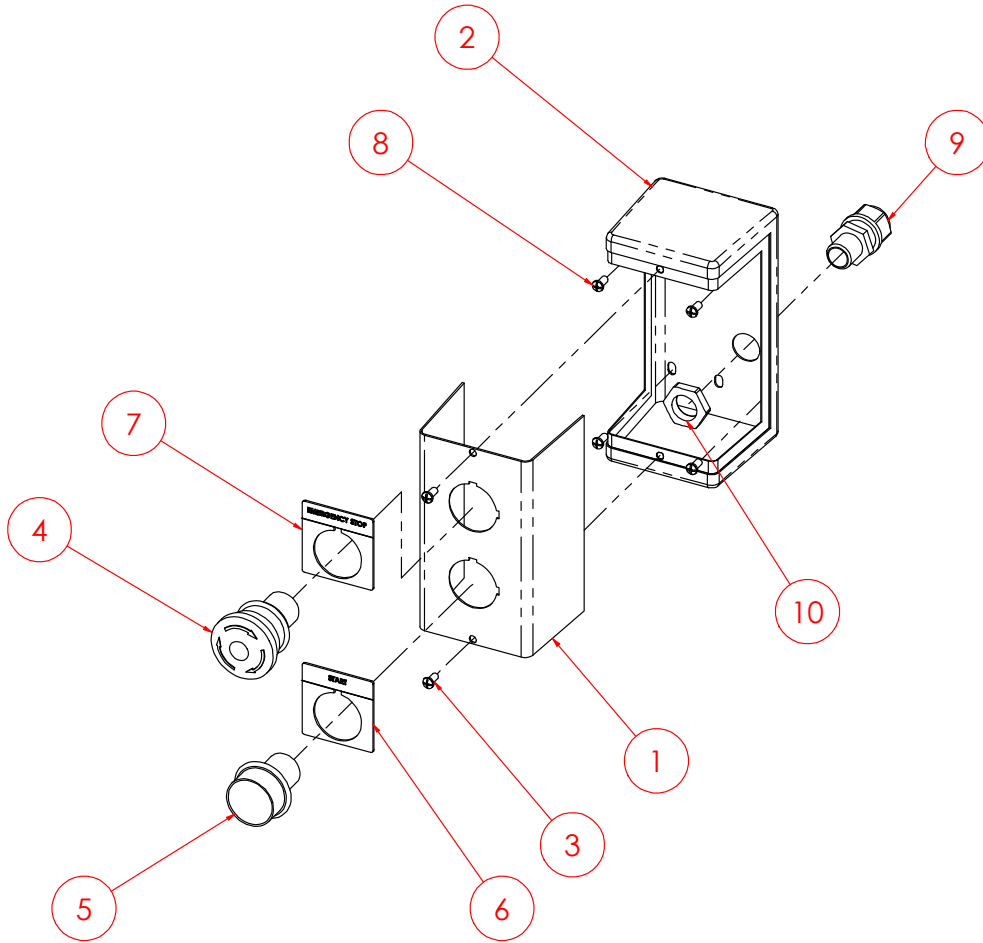

# STOP / START BOX

## (UAM1084)

ITEM	PART #	DESCRIPTION	QTY
1	UPM3962EV-it 1	COVER	1
2	UPM3962EV-it 2	BOX ELECT. 2 HOLES FOR BUTTON	1
3	UPM3962EV-it 3	PHCS M4-0.7 X 8mm	2
4	UPM0693EV	STOP BUTTON RED MUSH INC	1
5	UPM4514	ON/OFF GREEN BUTTON RSA	1
6	UPM0418	LEGEND PLATE "START"	1
7	UPM0419	LEGEND PLATE "EMERG.STOP"	1
8	UF9169	PHCS M4-0.7 X 8mm	4
9	UPM0197EV-16	STR.RELF METL.LIQDTGHT M16X1.5 (8-10mm )	1
10	UPM0341EV-16	LOCKNUT M16 X 1.5(FOR STRAIN RELF)	1

# ELECTRIC BOX INSTALLED (USM0808)

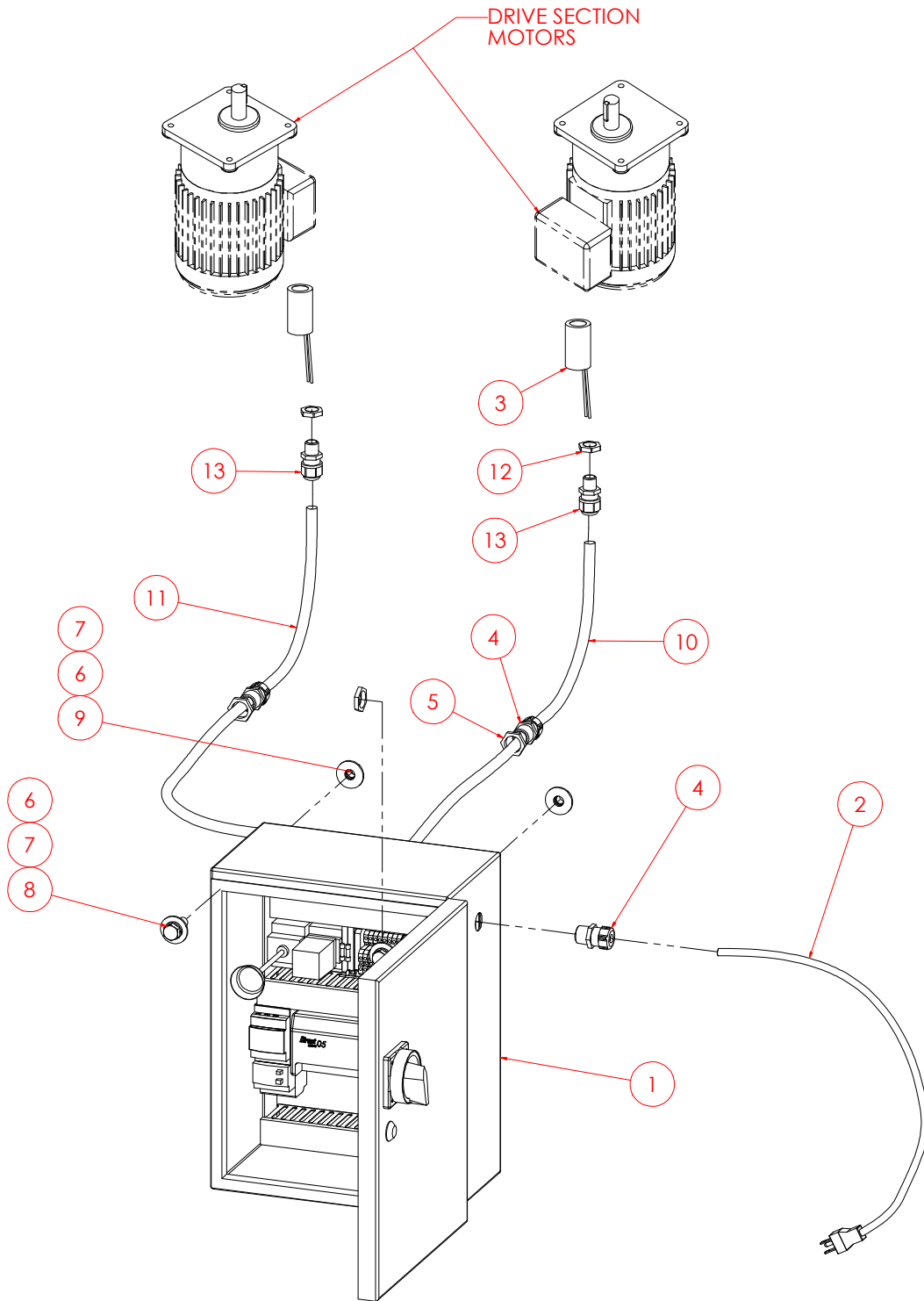

# ELECTRIC BOX INSTALLED (USM0808)

ITEM	PART #	DESCRIPTION	QTY.
1	UAM0295	ELECTRIC CONTROL BOX UA262024SB TW	1
2	UPM0209	POWER CORD, 14/3	1
3	UPM9719	CAPACITOR 16uF	2
4	UPM0197EV	STR.RELF METL.LIQDTGHT M20X1.5 (8-10mm)	3
5	UPM0341EV	LOCKNUT M20 X 1.5(FOR STRAIN RELF)	3
6	UF4231	FW M12	4
7	UF4230	L.W. ZINC M12	4
8	UF3062	HHCS M12-1.75 x 25	2
9	UF4234	HNR M12 x 1.75	2
10	UPM0225	CABLE 18/3 TYPE SJ	2.1m
11	UPM0225	CABLE 18/3 TYPE SJ	2.1m
12	UPM9728	LOCKNUT M16 X 1.5(FOR STRAIN RELF)	2
13	UPM9727	STR.RELF METL.LIQDTGHT M16X1.5 (8-10mm )	2

# ELECTRIC BOX ASSEMBLY (UAM0295)

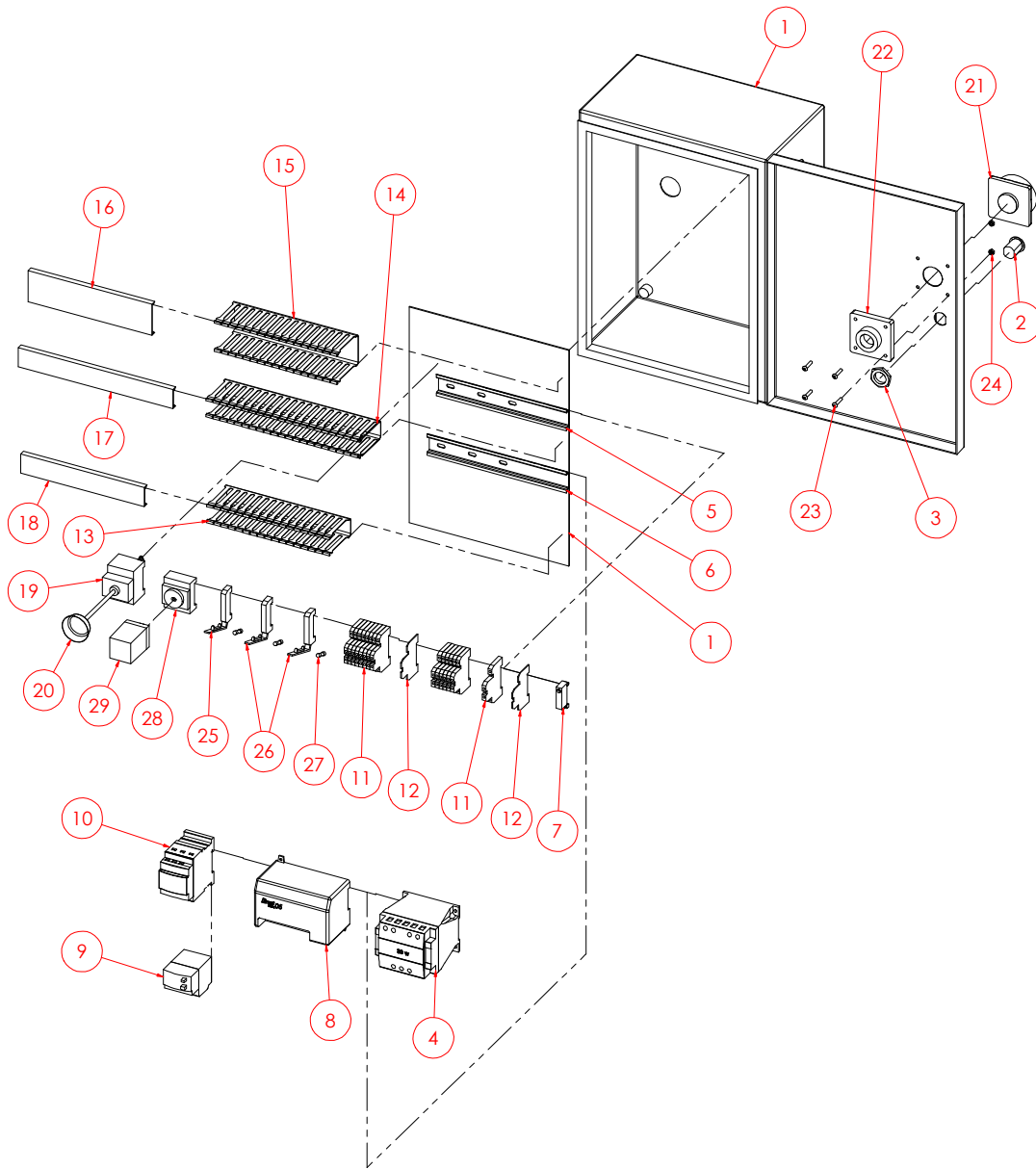

# ELECTRIC BOX ASSEMBLY (UAM0295)

ITEM	PART #	DESCRIPTION	QTY.
1	UPM3418EV	BOX ELECT. 400mm X 305mm X 150mm	1
2	UPM4465 it 1	CAM LOCK	1
3	UPM4465 it 2	UPM4465 LOCK NUT	1
4	UPM4458	POWER SUPPLY IDEC 1.3 A	1
5	UPM0407EV	DIN RAIL USA 2324	210mm
6	UPM0407EV	DIN RAIL USA 2324	225mm
7	UPM7440EV	TB END ANCHOR FOR DN SER	1
8	UPM3833	PLC KOYO 8IN VDC 6 OUT RELAY	1
9	UPM4505	MOTOR O/L TELEMEC 7-10A	1
10	UPM7524	MOTOR STARTER TELEMEC 110VAC	1
11	UPM2880EV	TERMINAL BLOCK DOUBLE TW	15
12	UPM2881EV	TERMINAL BLOCK DOUBLE END CAP	2
13	UPM226EV	WIRE WAY 30mm	200mm
14	UPM226EV	WIRE WAY 30mm	250mm
15	UPM254EV	WIRE WAY 50mm	200mm
16	UPM0255EV	COVER 50mm	200mm
17	UPM0177EV	COVER 30mm	250mm
18	UPM0177EV	COVER 30mm	200mm
19	UPM7211 it 1	ON / OFF SAF SWITCH CONT PANEL	1
20	UPM7211 it 2	UPM7211 EXTENSION ROD	1
21	UPM7211 it 3	UPM7211 POSITION INDICATOR S/A	1
22	UPM7211 it 4	UPM7211 CONNECTING S/A	1
23	UPM7211 it 5	BHCS M4 - 0.7 x 20	4
24	UPM7211 it 6	HEX NUT M4-0.7	4
25	UPM7428EV	FUSE TERMINAL BLOCK 5mm, WHITE LED	1
26	UPM4466	FUSE TERMINAL BLOCK 5mm, RED LED	2
27	UPM7120	FUSE 5mm X 20mm 1AMP/250V IEC	3
28	UPM9726	RELAY SOCKET	1
29	UPM4459	RELAY IDEC 24V 11 PINS	1



# SECOND E-STOP INSTALLED (OPTIONAL) (UM9003)

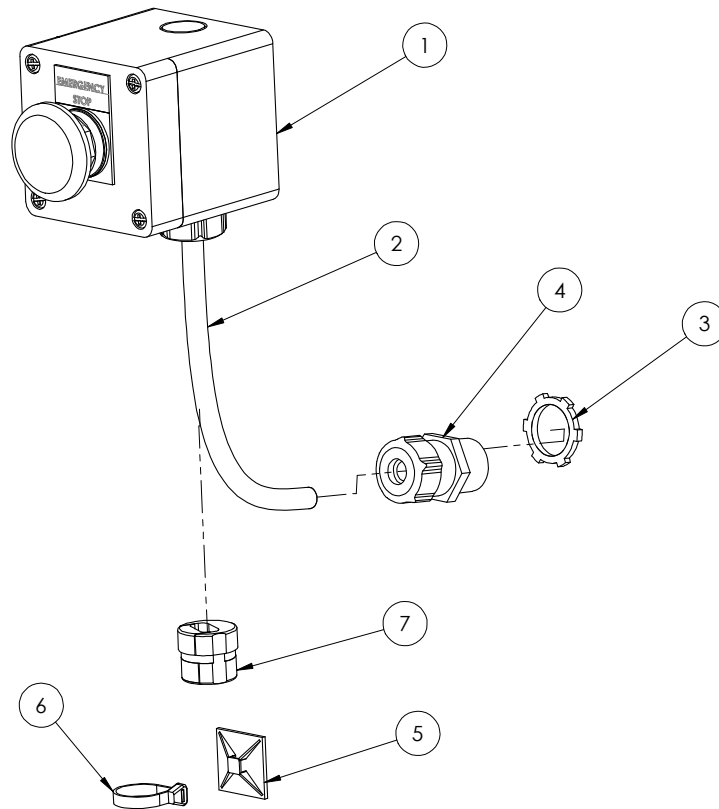

**SECOND E-STOP INSTALLED (OPTIONAL)**  
**(UM9003)**

ITEM NO.	PART NUMBER	DESCRIPTION	QTY.
1	USM8075	SECOND E-STOP BOX FOR USA	1
2	UPM0225	CABLE 18/3 TYPE SJ	2.0 m
3	UPM0341	LOCKNUT 1/2"(FOR STRAIN RELF)	1
4	UPM0197	STR.RELF METL.LIQDTGHT 1/4-3/8	1
5	UPM0200	MTG. CLAMP,ADH.1.2"X1.2"	4
6	UPM0222	TY-RAP,5.5"X.14"	4
7	UPM0285	STRAIN RELIEF, NON-METAL	1

# SECOND E-STOP BOX ASSEMBLY (OPTIONAL) (USM8075)

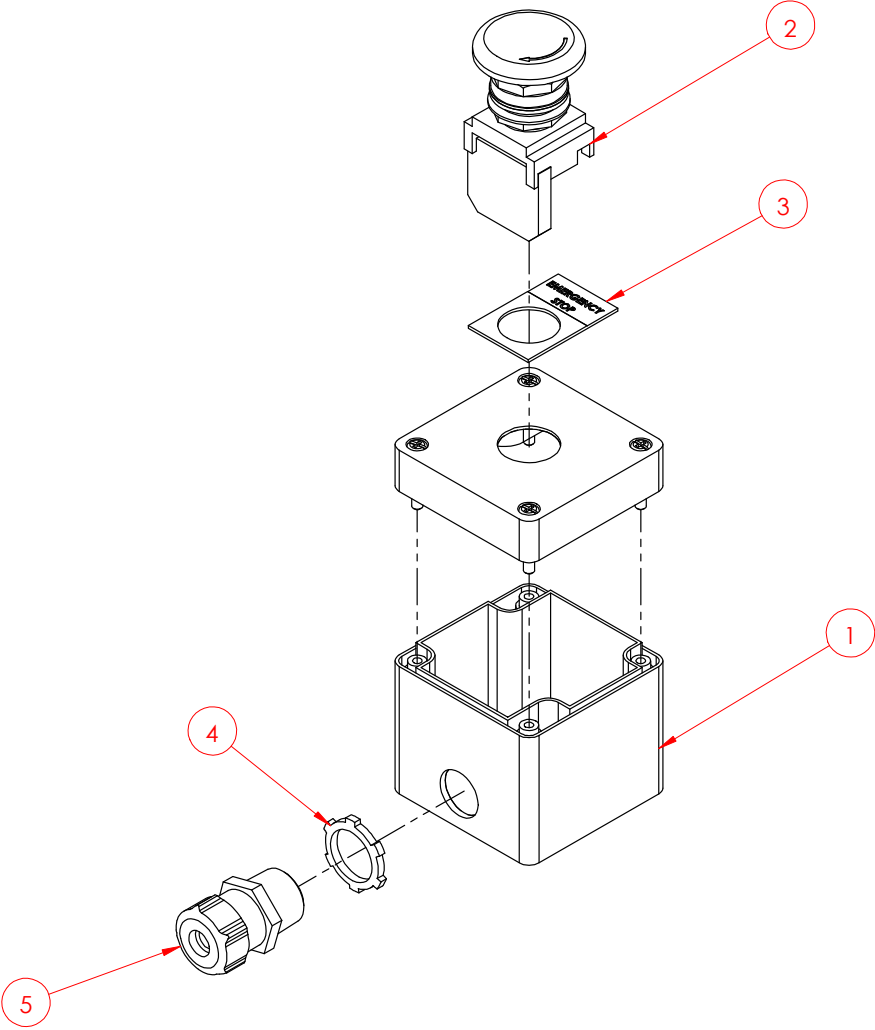

**SECOND E-STOP BOX ASSEMBLY (OPTIONAL)**  
**(USM8075)**

ITEM NO.	PART NUMBER	DESCRIPTION	QTY.
1	UPM7293	ENCLOS PB 1 HOLE NON METAL	1
2	UPM2211	BUTTON MUSHROOM 22MM 1 N.C.	1
3	UPM2209	LEGEND PLATE "E-STOP"	1
4	UPM0341	LOCKNUT 1/2"(FOR STRAIN RELF)	1
5	UPM0197	STR.RELF METL.LIQDTGHT 1/4-3/8	1

# ELECTRIC DIAGRAM

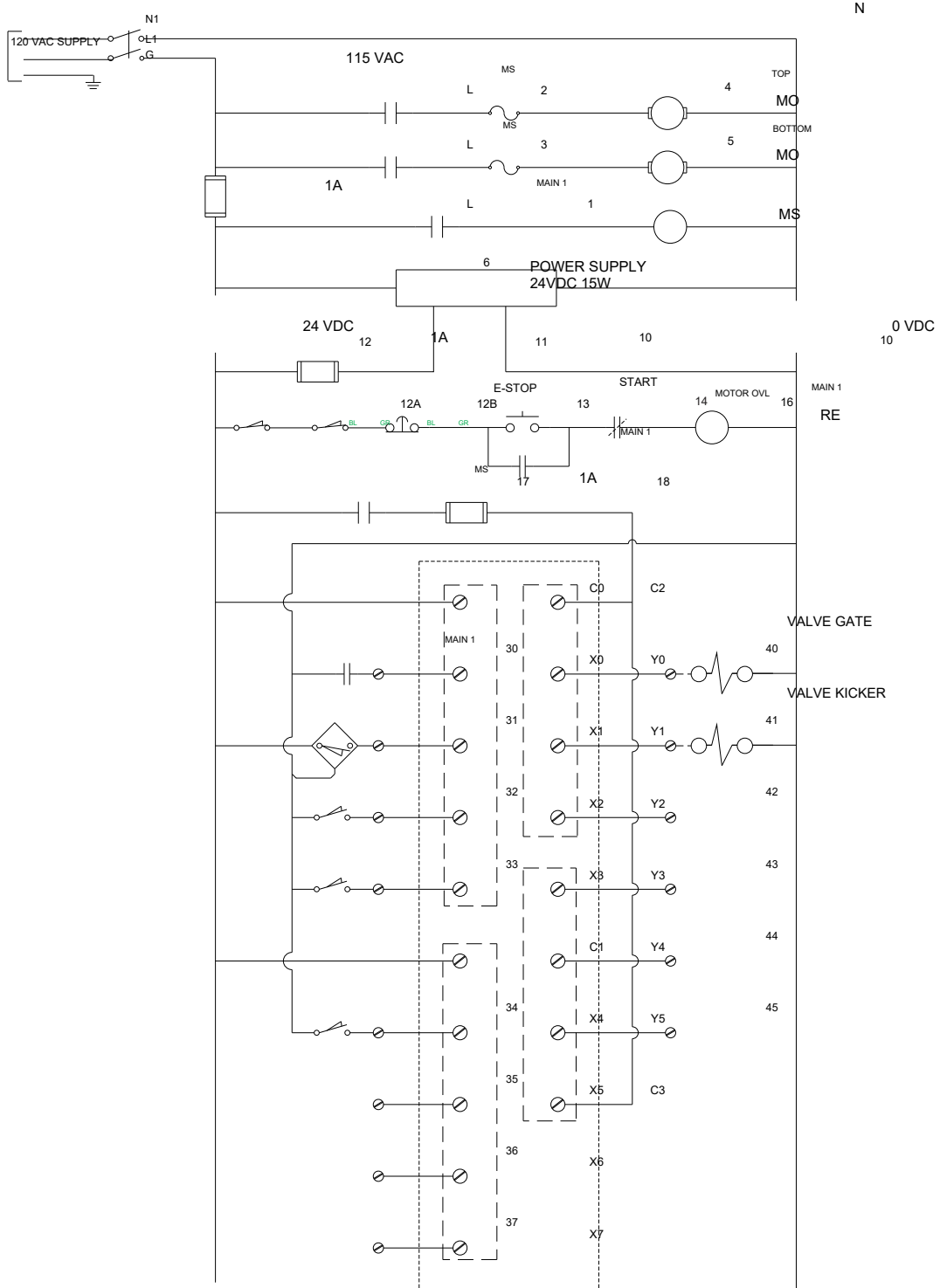

# PNEUMATIC DIAGRAM

