



# USER MANUAL AIR 3 PRO



# USER NOTES

---

For all IPG product manuals please visit [www.itape.com/systems-manual](http://www.itape.com/systems-manual) or use this QR code



# TABLE OF CONTENTS

---

<b>General Information</b>	<b>4</b>
Preface	4
Machine, Stands and Accessories Set-Up	4
Machine Product Description	4
Technical Support	4
Field Service Assistant	4
Definitions	4
<b>Machine Overview</b>	<b>5</b>
Machine Identification	5
<b>Important Safety Instructions</b>	<b>6</b>
Explanation of Signal Word Consequences	6
Safety Components	8
Warning and Caution Labels	9
<b>Intended Use</b>	<b>10</b>
Intended Use of AirSpace 3 Pro	10
<b>Technical Specifications</b>	<b>11</b>
Film Specifications	11
<b>Machine Operations</b>	<b>12</b>
Component Layout	12
<b>Machine Set-up</b>	<b>14</b>
<b>Machine Controls</b>	<b>16</b>
Machine Modes of the IPG AirSpace 3 Pro© Machine	17
Installing Film Onto the Machine and Operating the Machine's Modes	17
Preset Length Mode:	18
Sensor Mode:	18
Continuous Mode:	18
Service Mode:	18
<b>Bubble on Demand</b>	<b>19</b>
Bubble on Demand Accessories	19
Bubble on Demand Settings	20
Bubble on Demand Film Specifications	20
Bubble on Demand Film Loading	21
<b>Maintenance</b>	<b>22</b>
Inspection, Maintenance, and Repair	22
Operator Weekly Inspection Interval	22
Preventative Maintenance Interval	22
<b>Troubleshooting</b>	<b>24</b>
General Troubleshooting	24

# GENERAL INFORMATION

---

## Preface

This user manual contains information necessary to become familiar with the IPG AirSpace 3 Pro© system. It is intended to be used by the installer and end user of the IPG AirSpace 3 Pro©. It is necessary to read this manual carefully before use, this manual only applies to the IPG AirSpace 3 Pro©. This manual should be easily accessible at all times for the user and should be kept in close proximity to the IPG AirSpace 3 Pro© at all times. If the manual becomes damaged or you wish to request a new one please contact [IPG Machinery Support](#) for a new digital copy.

Please refer to the table of contents of this User Manual to locate the information relevant to you. Please be sure to keep this User Manual in a safe and convenient place, **close to the Machine**, to refer to it whenever necessary.

This User Manual is originally written in English. All other languages are translations of the original. For more information, or to order new User Manuals, please contact **Nuevopak**, an **IPG Company**, or an authorized representative.



**THIS IPG AIRSPACE 3 PRO© USER MANUAL CONTAINS IMPORTANT INFORMATION RELATED TO SAFETY, INTENSION AND MEANING OF THE MACHINE LABELS, MACHINE OPERATIONAL MODES AND THE GENERAL FUNCTIONS OF THE IPG AIRSPACE 3 PRO© AND ITS ACCESSORIES.**

## Machine, Stands and Accessories Set-Up



**CAUTION: PLEASE REFER TO THE SET-UP DOCUMENT FOR THE INITIAL SET UP OF THE MACHINE. FAILURE TO DO SO CAN RESULT IN INJURY OR DAMAGE TO THE MACHINE.**

## Machine Product Description

The **Machine** converts a roll of film into a protective void fill and shock absorbing packaging material. The **Machine** is an electrically driven feeding **Machine** that consists of a dispensing mechanism, inflating mechanism, and sealing mechanism. In the **Machine**, the film is blown into a protective void fill and shock absorbing packaging material through an air filling and heat sealing process.

## Technical Support

If any problems arise with this **Machine** during the normal course of operation, your properly trained and qualified internal service personnel should be able to repair any issues after consulting the [“General Troubleshooting” section on page 4](#).

Technical Support can be reached via phone in North America by calling 813-345-3070 or by email at [machsupp@itape.com](mailto:machsupp@itape.com)

## Field Service Assistant

For technical information and troubleshooting assistance, contact Technical Support. Internal qualified service personnel; please refer to the attached Business Card or the Identification Plate for contact information.

## Definitions

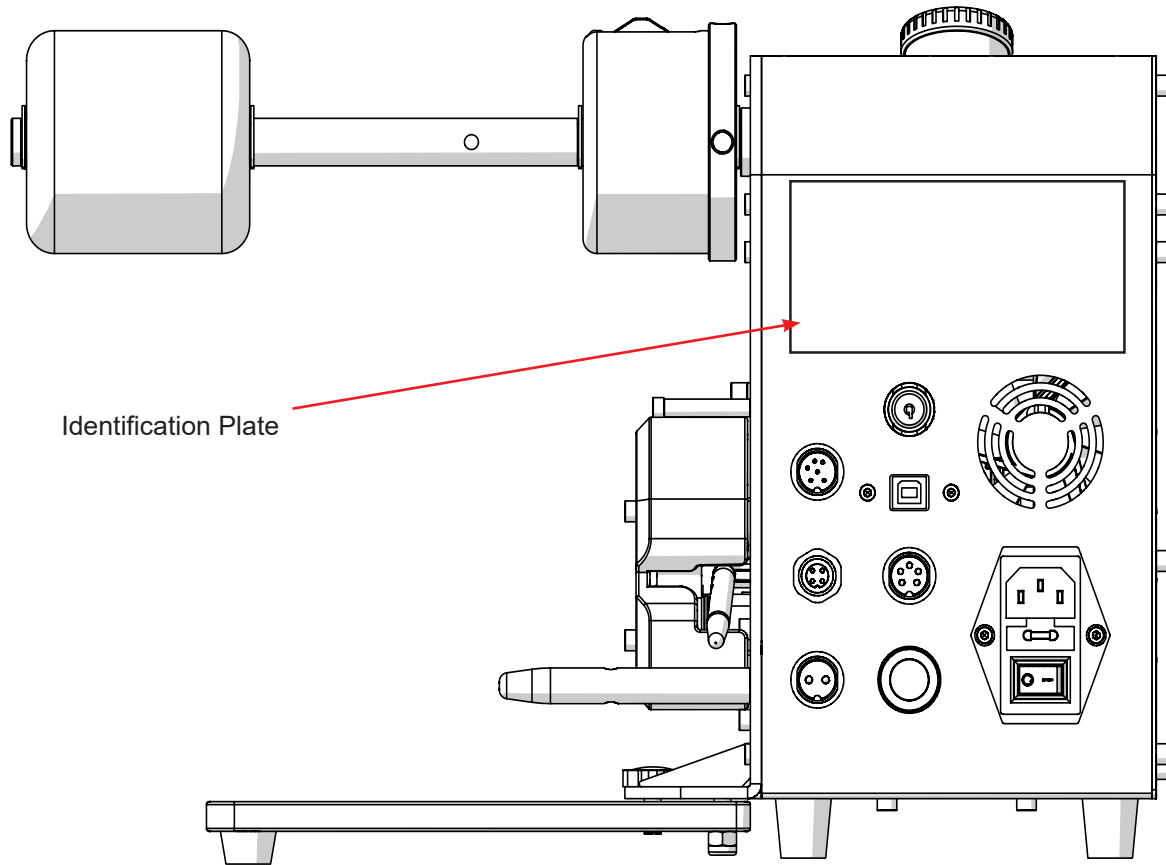
Throughout this manual there are common terms and phrases used. They are listed below:

1. The **Machine** is defined as the IPG AirSpace 3 Pro© which is manufactured by **Nuevopak**, an **IPG Company**.
2. The **Installer** is defined as that individual who have been trained by **Nuevopak**, an **IPG Company** representative and are authorized to install and operate the system as outlined in this User Manual.
3. The **Operator** or **User** is defined as that individual who have been trained by internal qualified service personnel or **Nuevopak**, an **IPG Company** representative and is authorized to Operate the system as outlined in this guide.
4. The **Trainer** is the individual, who has been trained by an IPG authorized representative, who is responsible for overseeing all User/Operators of use of The **Machine**.
5. An **Authorized Representative** or **Qualified Service Personnel** are defined as those individuals who are authorized to: install the **Machine**, operate the **Machine**, train users, train qualified service personnel, and to perform all maintenance and repair procedures other than outlined in this User Manual.

# MACHINE OVERVIEW

## Machine Identification

The **Machine** identification is located on the **Identification Plate** which is attached to the back of the **Machine** (refer to Figure 1).



Model and Power Requirements

Serial Number

Technical Support

Manufacturer Details

The identification plate contains the following information:

- ipg<sup>®</sup> intertape polymer group<sup>®</sup>
- AIRSPACE™ A3PRO**
- Model: AirSpace A3 PRO
- Electrical: 100V-240V~Single Phase 2.4A 50/60Hz
- Short Circuit Current Rating: 1.5kA
- S/N: ASD-300001
- Machinery Technical Support Options to Better Serve You:  
**Toll-free (877) 447-4832**  
**Direct (813) 345-3070**
- This equipment is manufactured by Intertape Polymer Group Inc.  
100 Paramount Drive, Suite 300, Sarasota, FL 34232, USA  
www.itape.com
- MANUFACTURED DATE: 2022.02
- CAN ICES-3(A)/NMB-3(A)  
Main Document No : ASD-E0001
- Certifications: UK, CA, CE, TÜV, and other safety symbols.

**Machine** Certifications.  
These may vary by  
**Machine** type/country.

Manufacturing  
Date

Figure 1: Machine Identification

## Safety Precaution



**THE MACHINE IS DESIGNED FOR SAFE USE IN CONFORMANCE WITH THE APPLICATION, CONDITIONS AND RULES DESCRIBED IN THIS USER MANUAL. ALL USERS MUST READ AND UNDERSTAND THIS MANUAL BEFORE OPERATING THE MACHINE.**

# IMPORTANT SAFETY INSTRUCTIONS

---

## Explanation of Signal Word Consequences



**THIS SYMBOL CALLS ATTENTION TO CAREFULLY READ THE STATEMENT AS IT IS CRITICAL FOR MACHINE OPERATION.**



**THIS SYMBOL CALLS ATTENTION TO CONDUCT PROPER LOCK OUT TAG OUT (LOTO) PROCEDURES PRIOR TO CONDUCTING ANY PREVENTATIVE MAINTENANCE OR MACHINE MAINTENANCE.**



**WARNING: INDICATES A POTENTIALLY HAZARDOUS SITUATION, WHICH IF NOT AVOIDED COULD RESULT IN DEATH OR SERIOUS INJURY OR PROPERTY DAMAGE**



**CAUTION: INDICATES A POTENTIALLY HAZARDOUS SITUATION, WHICH IF NOT AVOIDED COULD RESULT IN MINOR OR MODERATE INJURY OR PROPERTY DAMAGE**



**WARNING**

- 1. To reduce the risk associated with mechanical and electrical hazards:**
  - Read, understand, and follow all safety and operating instructions before operating or servicing the AirSpace 3 Pro©
  - Allow only properly trained and qualified personnel to operate and service this equipment
- 2. To reduce the risk associated with pinches, entanglement, and hazardous voltage:**
  - Turn electrical supply off and disconnect before performing any adjustments, maintenance, or servicing
- 3. To reduce the risk associated with pinches and entanglement hazards:**
  - Do not leave the AirSpace 3 Pro© running while unattended
  - Turn the AirSpace 3 Pro© off when not in use
  - Never attempt to work on any part of the AirSpace 3 Pro© while the **Machine** is running
- 4. To reduce the risk associated with hazardous voltage**
  - Position electrical cord away from foot traffic and vehicle traffic
  - Do not operate the AirSpace 3 Pro© with a damaged power cord
- 5. To reduce the risk associated with sharp blades hazards:**
  - Keep hand and fingers away from the AirSpace 3 Pro© blade, the blade is very sharp
- 6. To reduce the risk associated with fire and explosion hazards:**
  - Do not operate this equipment in potentially flammable and/or explosive environments
- 7. To reduce the risk associated with muscle strain:**
  - Use proper body mechanics when removing or installing film rolls that are moderately heavy or may be considered awkward to lift
- 8. To reduce the risk associated with mechanical and electrical hazards:**
  - Allow only properly trained and qualified personnel to operate and service this equipment
  - Do not operate the **Machine** when the side plate covers or belt covers are damaged or removed



**CAUTION**

- 1. To reduce the risk associated with pinch hazards:**
  - Keep hands, hair, loose clothing, and jewelry away from box compression rollers, moving belts, and Tape Heads

# **IMPORTANT SAFEGUARDS**

---

## **Operational Safety**

In the event of a defect, or if the operation of the **Machine** differs from the descriptions in this User Manual, turn the I/O Main Switch to [O] OFF and disconnect the Power Cord from the main power until the unit can be inspected by a trained Nuevopak, an IPG Company representative, or qualified service personnel.

- Make sure that cords cannot be and are not damaged.
- Before moving the **Machine**, unplug the Main Power Cord, Photo Eye Cable, and other accessories from the **Machine** back and secure loose cords.
- Make sure the **Machine** is acclimated for at least 30 minutes when moved from a cold area.
- Do not use cable reels. An extension cable with a wire gauge of at least 14 AWG (1,5mm<sup>2</sup>) with a maximum length of 11.5 ft (3.5m) may be used.

## **Precautionary Statements**

There are a number of Warning and Caution labels used on the **Machine**, these labels are placed at different locations on the **Machine** to warn the Installer, Operator(s) and Service Personnel of possible dangers (Figure 2). Please refer to this User Manual of the IPG AirSpace 3 Pro© to get familiar with the meaning of the warning and caution labels on the **Machine** before using the **Machine**.

## **Warning Label Descriptions**

The **Machine** and its accessories are provided with Warning and Caution labels. **Do not remove any warning or caution labels** and keep them undamaged. In case a Warning or Caution label is damaged, contact **Nuevopak, an IPG Company**, or an authorized representative for replacement labels.

# IMPORTANT SAFEGUARDS

## Safety Components

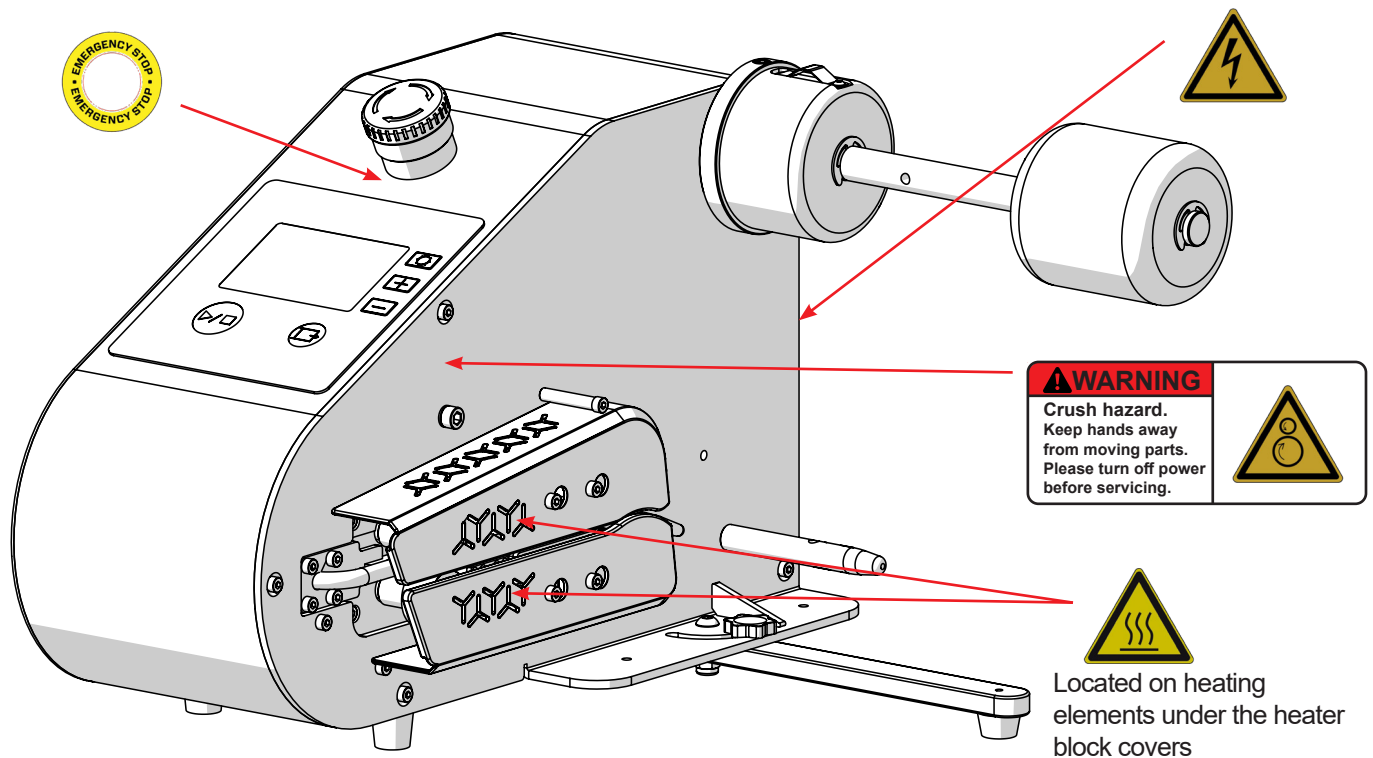


**WARNING! DO NOT REMOVE OR TAMPER WITH THE SAFETY COMPONENTS. DO NOT REMOVE THE COVERS. THE ACCESS COVERS MAY ONLY BE REMOVED BY AN AUTHORIZED NUEVOPAK/IPG REPRESENTATIVE OR QUALIFIED SERVICE PERSONNEL THAT HAVE BEEN TRAINED BY A NUEVOPAK/IPG REPRESENTATIVE.**

The following is a list (Table 1) and illustration (Figure 2) of the safety components and warning labels which are part of the **Machine**.

**Table 1: Safety Components**

Safety Component	Description
Emergency Stop Button (E-Stop)	This switch, located on the top of the <b>Machine</b> , interrupts the power to the entire <b>Machine</b> when pushed.
Access Panel	Panel preventing the user to access the <b>Machine</b> interior components.
Heater Block Covers	The Heater Block Covers prevent the user to access the moving drive belts and heated components of the <b>Machine</b> .
Fuse	10 amp 250 volt, 5 x 20mm





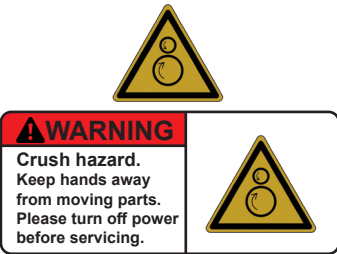







**Figure 2: Safety Label Placement**



# IMPORTANT SAFEGUARDS

## Warning and Caution Labels

Table 2: Warning and Caution Labels

Symbol	Meaning
	Read the instruction manual/booklet before starting work or before operation the Machine.
	Disconnect the main power cord for maintenance purposes, in case of malfunction or when the Machine is left unattended.
	Do not put hands into designated openings. Crush hazard.
	Hot surface. Allow time to cool before servicing.
	Take care to avoid injury to hands when in the surrounding area of equipment with closing or adjusting mechanical parts.
	Take care to avoid injury from sharp elements.
	Take care when in the surrounding area of a floor that is not level, tripping hazards exist.
	Electricity. Take care to avoid coming into contact with electricity.
	Do not push or lean against the Machine when stationary or attached to any accessories.
	Emergency Stop. Use this button to interrupt the power to the entire Machine.

# INTENDED USE

---

## Intended Use of AirSpace 3 Pro



**CAUTION! USING THE MACHINE BEYOND ITS CAPABILITY, BEYOND THE PHYSICAL USER CONDITIONS, OR WITHOUT FOLLOWING THE SAFETY PRECAUTIONS AS DESCRIBED IN THE SET-UP MANUAL AND THIS USER MANUAL CAN BE CONSIDERED AS MISUSE. READ THIS USER MANUAL BEFORE STARTING WORK OR BEFORE OPERATING THE MACHINE.**

1. The Void Fill Product created by the **Machine** is intended to be used only as packaging material.
2. Only Void Fill products which are intended to be used for the **Machine** and which are supplied by an **IPG** authorized representative may be used.
3. Only accessories which are intended to be used for the **Machine** and which are supplied by an **IPG** authorized representative may be used.
4. Connect the **Machine** to a properly grounded outlet only.
5. To disconnect, turn the I/O Main Switch to O [OFF] and disconnect the Main Power Cord from the main power outlet.
6. Do not unplug cables by pulling on cord. To unplug grasp the plug, not the cord.

The following applications or acts are not suitable for the **Machine** and constitute improper use:

1. **DO NOT** use a Film Void Fill product other than those produced and supplied by a **Nuevopak** or **IPG Company** representative and intended for use on the **Machine**.
2. **DO NOT** use outside or in humid conditions.
3. **DO NOT** use in potentially explosive environments.
4. **DO NOT** wash or clean the **Machine** with excessive quantities of water.
5. **DO NOT** stand on the **Machine** or its stand/accessories.
6. **DO NOT** place objects against or on top of the **Machine**.
7. **DO NOT** move the **Machine** while the power plug is still connected to the AC power supply.

## Disclaimer

The intended use of the **Machine** is to convert film, from a wound roll, into void fill material. **Nuevopak**, an **IPG Company**, and its authorized representatives are not responsible for any accidents, damages or errors caused by:

1. Not following the instructions and illustrations as described in this **Machine** user manual.
2. Use of components which are not supplied by **Nuevopak**, an **IPG Company**, or an authorized representative.
3. Repairs or modifications done by anyone other than a **Nuevopak**, an **IPG Company**, authorized representative or a **Nuevopak**, an **IPG Company**, trained service technician.
4. Improper use or alternation to any of the original parts of the **Machine**.
5. Not keeping the **Machine** covers attached with the provided tamper-proof screws.



**WARNING! DO NOT REMOVE OR TAMPER WITH THE SAFETY COMPONENTS. DO NOT REMOVE THE COVERS. THE ACCESS COVERS MAY ONLY BE REMOVED BY AN AUTHORIZED NUEVOPAK/IPG REPRESENTATIVE OR QUALIFIED SERVICE PERSONNEL THAT HAVE BEEN TRAINED BY A NUEVOPAK/IPG REPRESENTATIVE.**

# TECHNICAL SPECIFICATIONS

**Table 3: Technical Specifications**

<b>Machine Component</b>	<b>Specification</b>
Dimensions	15.7" x 7.3" x 10.6" (400 mm x 186 mm x 270 mm)
Weight	24.5 lbs (11 kg)
Weight with roll of film installed	50 lbs (23 kg) weight of film may vary based on style
Maximum sound pressure level	69dB(A) +/- 2.5dB(A)
Non-ionizing radiation	Not applicable
IP class	IP 20
Installation class	Class I
Supply voltage (U)	100 – 120, 1PH
Frequency	50-60 Hz
Current (I)	2.4 A (110VAC)
Power (P)	0.26KW (110VAC)
Fuse rating (A)	10 A (250VAC)
Electric receptacle	15 A (110VAC)
Color	White and Black
Construction	Metal frame and covers
Accessories mechanical construction	Steel
Storage temperature	-4 - 122°F (-20- 50°C)
Operation temperature	41 - 104°F(5 - 40°C)
Storage humidity	"Dry" ~ 95% (in protective packaging)
Operating humidity	30 ~ 90%, non-condensing
The electrical equipment shall be capable of operating correctly when the relative humidity does exceed 90% at a maximum temperature of 68°F (20°C).	
Electrical equipment shall be capable of operating correctly at altitudes up to 6,562 ft. (2,000m) mean sea level.	

## **Film Specifications**

The IPG AirSpace 3 Pro© is capable of processing a variety of film and film types, this includes Bubble on Demand (BoD). Use only IPG approved void fill film in the AirSpace 3 Pro. See the set up document for more details on the film settings.

# MACHINE OPERATIONS

## Component Layout

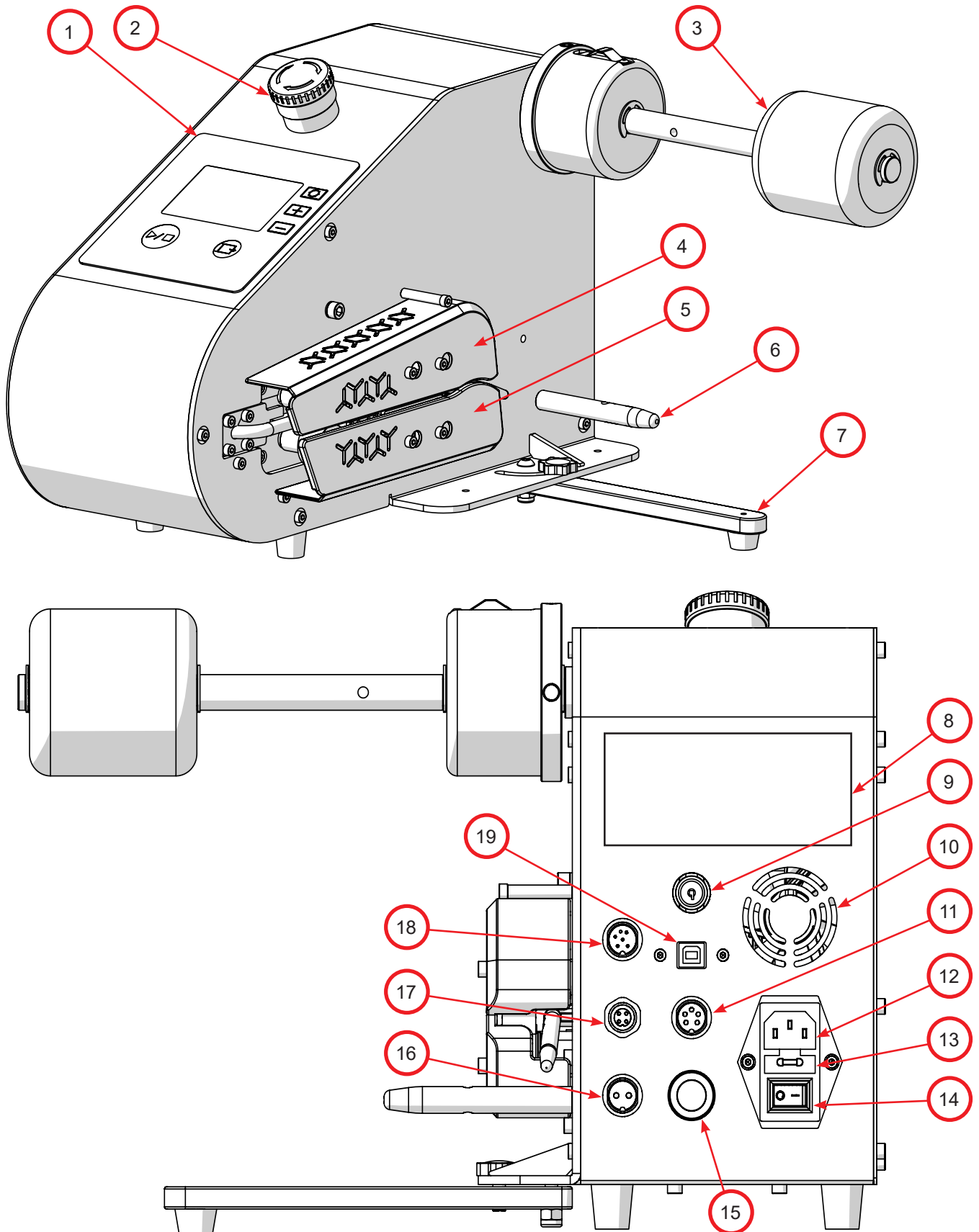


Figure 3: Component Layout

# MACHINE OPERATIONS

## Component Layout

Legend	
Item No.	Description
1	User Control Panel
2	Emergency Stop Button
3	Film Roll Holder
4	Heater Block Upper Cover
5	Heater Block Lower Cover
6	Film Guide
7	Support Leg
8	Identification Plate
9	Service Mode Key Switch
10	Cooling Fan
11	Port 4 – External Air Pump used with custom applications
12	Main Power Socket
13	Fuse – 10 amp 250 volt, 5 x 20 mm
14	Main Power Switch
15	Air Pump Connection – This port is used in conjunction with custom applications
16	Port 1 – Foot switch. This port is designed to be operated with the optional foot switch accessory
17	Port 2 – Photo Eye. This port is designed to take the optional photo eye accessory to automatically turn on and off the <b>Machine</b> .
18	Port 3 – Winder Communication Connection
19	USB Port

# MACHINE SET-UP

The IPG AirSpace 3 Pro© can be set up by an IPG Authorized Trainer. The trainer will be provided a set up document for the **Machine**.

Required for safe use of the **Machine** by the Operator, ensure the **Machine** gets installed by the Installer according to the Operational limits as shown below.



**WARNING! MAKE SURE THERE IS ONLY ONE PERSON PRESENT IN THE WORK AREA WHEN THE MACHINE IS OPERATED.**

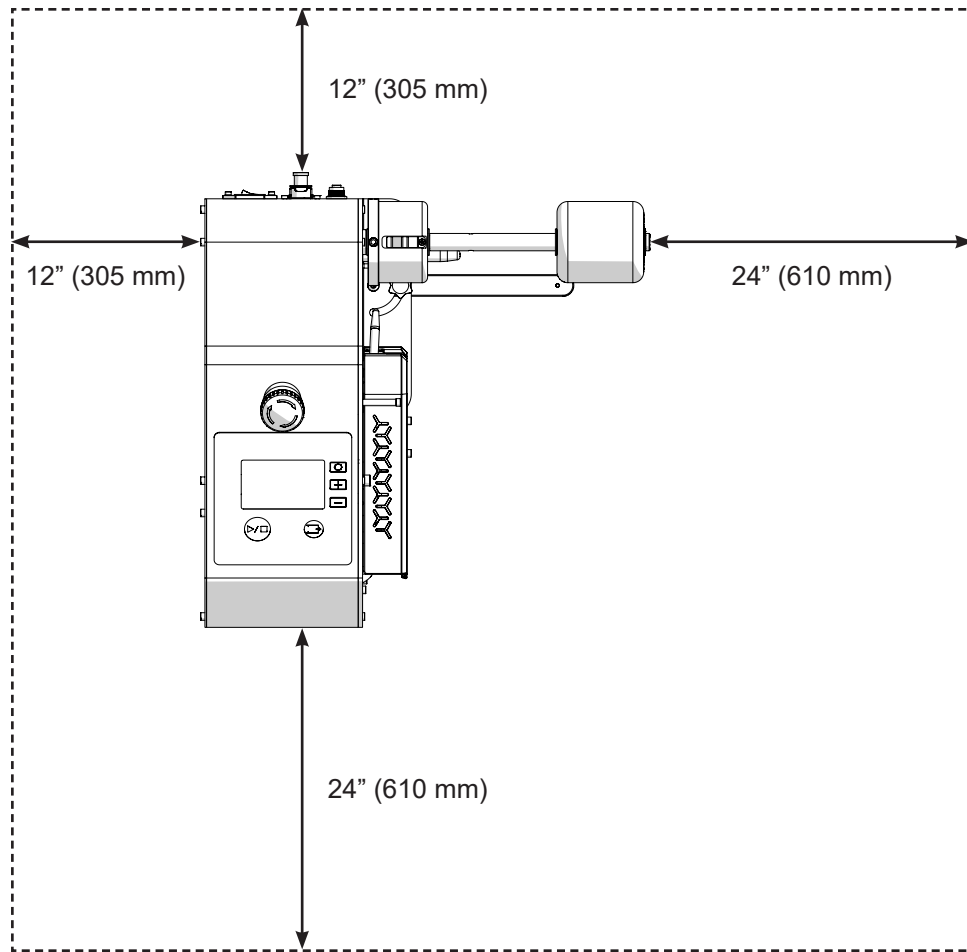


Figure 4: Safe Zone



**WARNING! FAILURE TO PROPERLY GROUND THE SYSTEM COULD CREATE AN ELECTRICAL SHOCK HAZARD.**

A qualified electrician should be consulted if there is any doubt as to whether an Main Power wall Socket is properly grounded.

Do not use outdoors.



**WARNING! NEITHER THE MACHINE NOR ITS ACCESSORIES ARE INTENDED FOR USE WITH OR AROUND POTENTIALLY FLAMMABLE OR EXPLOSIVE MATERIALS.**

# MACHINE SET-UP

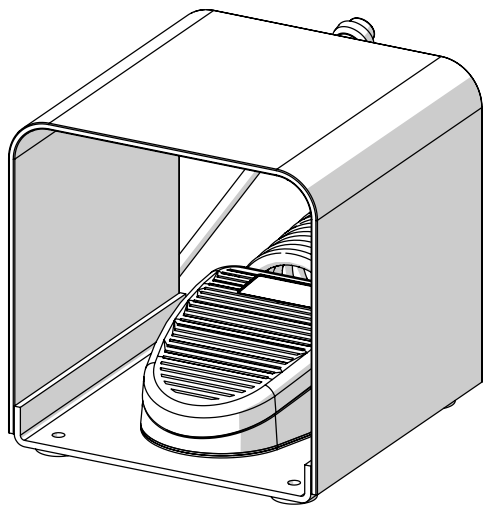
---

## Machine Accessories Overview

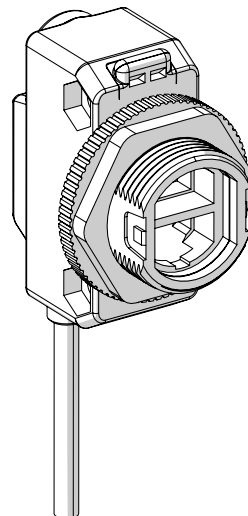
The **Machine** can be set-up with the following accessories:

1. Foot Switch (Figure 5).
2. Photoeye Sensors (Figure 6).

**NOTE:** The available accessories depend on the Machine configuration ordered. Not all accessories may be available.

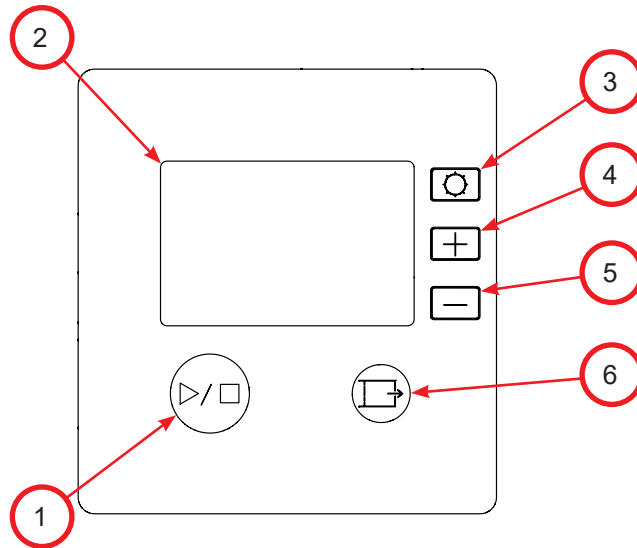


**Figure 5: Foot Switch**



**Figure 6: Photoeye Sensor**

# MACHINE CONTROLS



**Figure 7: Machine Controls**

LEGEND	
Item No.	Description
1	Start/Stop Button – This button will begin the normal function of the <b>Machine</b> , processing film and turning it into Void Fill Pillows, pressing the button a second time stops the <b>Machine</b> .
2	LCD Screen – This will display all current settings
3	Setting Button – When in Service Mode this button will change the selected option on the screen.
4	(+) Button – When in Service Mode use this button to increase the value of the selected option on the screen
5	(-) Button – When in Service Mode use this button to decrease the value of the selected option on the screen
6	Film Jog Button – Press and hold to advance the belts for loading film



# MACHINE CONTROLS

## Machine Modes of the IPG AirSpace 3 Pro© Machine

The **Machine** is designed to operate in several modes with a variety of accessories and is able to be adjusted to accept a wide variety of film. Some adjustments may need to be made to accommodate small discrepancies in film manufacturing from batch to batch. Please consult the film addendum for baseline settings on film.

## Installing Film Onto the Machine and Operating the Machine's Modes

1. Ensure any accessories are properly connected to the **Machine's** rear panel.
2. Ensure the Main Power Connection is properly connected to the **Machine** and wall socket.
  - Verify the power cord is not damaged
3. The **Emergency Stop button** is not pressed.
4. Turn the **Machine ON** by switching the **I/O Main Switch** on the rear of the **Machine** to the [I] position.
5. Verify the **Machine** settings are set to the desired settings for your film.
6. Place the **Roll of Film** over the mandrel and verify it is fully seated.
  - Film should peel off the roll over the top towards the rear of the **Machine**. Follow the Film Threading Path for details. The film should pass under the film guide before being placed over the nozzle.
7. Place the film air channel over the nozzle of the **Machine** until it reaches the belts.
8. Use the "Film Jog" button (Figure 9) by pressing and holding, to advance the film through the belts of the **Machine**.

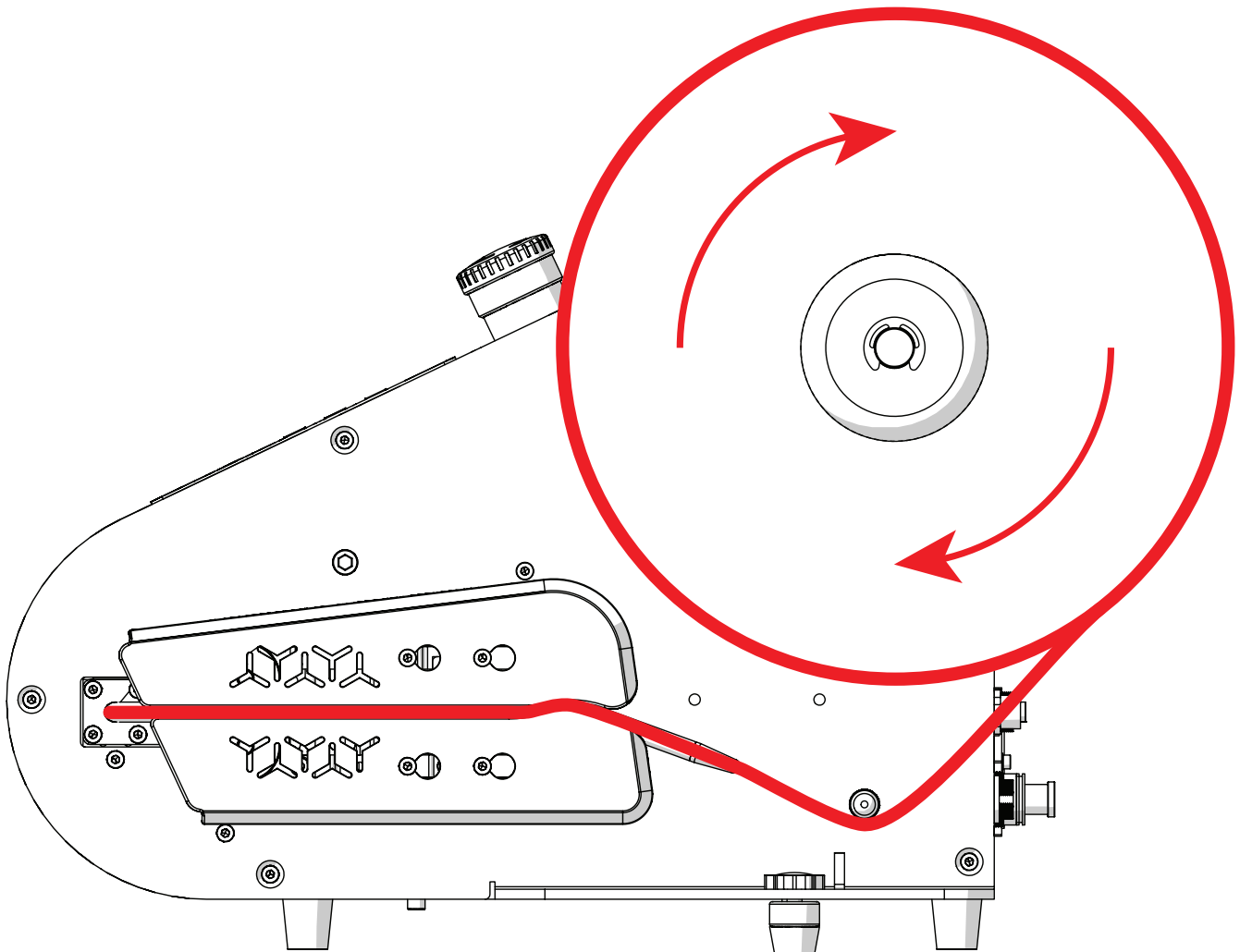


Figure 8: Film Threading Path for Pillows

# **MACHINE CONTROLS**

---

## **Preset Length Mode:**

When changing the preset length to any value other than “0000” the Machine will produce a string of pillows to the set value in feet.

**Separate the dispensed string of air pillow void fill by tearing it manually off the string at the pack station.**

## **Sensor Mode:**

To enter Sensor Mode turn the **Machine** off and plug a photo eye into Port 2. The **Machine** will automatically enter sensor mode when a photoeye (Figure 6) is plugged into Port 2 and powered on. This will provide a pack station with a constant supply of pillows, operator free.

**In Sensor Mode, the Machine will continue to dispense air pillows into a hopper until the sensor has been covered for four (4) seconds. Once the sensor has been covered the Machine will pause production.**

**Separate the dispensed string of air pillow void fill by tearing it manually off the string at the pack station.**

**The Machine will begin dispensing Air Pillows when the supply in the hopper has dropped below the sensor and it has been clear for four (4) seconds.**

## **Continuous Mode:**

When the preset length setting is set to “0000” the **Machine** will operate in a continuous mode. In this mode a foot switch can be used to control the start/stop functionality of the **Machine**.

**Separate the dispensed string of air pillow void fill by tearing it manually off the string at the pack station.**

## **Service Mode:**

When the **Machine** is in service mode it is possible for the trainer/technician to modify settings on the **Machine**. This may require a service key to engage this mode. A set of service keys is included in the spare parts box included with the **Machine**.

If your **Machine** has a key switch, a key is **required** to access Service Mode. Insert the key and rotate it. When the **Machine** is in Service Mode you will see a “\*” on the screen. Make any changes necessary for fine tuning. Once the changes have been made, switch the key back to its home position and remove it from the **Machine**. When the “\*” is no longer on the display your settings are locked in and cannot be accidentally changed.

**While in Service Mode, the Machine will continue to dispense air pillows in the same manner of the previous operation mode, Continuous Mode or Sensor Mode.**

**When finished making adjustments, be sure to disengage Service Mode as to not accidentally change desired settings.**

If your **Machine** does not have a key slot on the rear panel, Service mode can be engaged by holding down the Setting Button and the - Button at the same time for 5 seconds. After this you will see a “\*” on the screen notifying you that the **Machine** is in Service Mode. To lock the **Machine** settings, hold down the Setting Button and the - Button at the same time for 5 seconds. Once the “\*” goes away from the screen, the **Machine** settings are saved and locked.

# BUBBLE ON DEMAND

---

The IPG AirSpace 3 Pro<sup>®</sup> can be configured by the factory to process Bubble on Demand or BoD film. This BoD version of the IPG AirSpace 3 Pro<sup>®</sup> has some unique features that make it physically different from the standard version of the machine. There is a second film guide to block the air from reaching the main roll and the nozzle is a different diameter to better accommodate the differences in film.

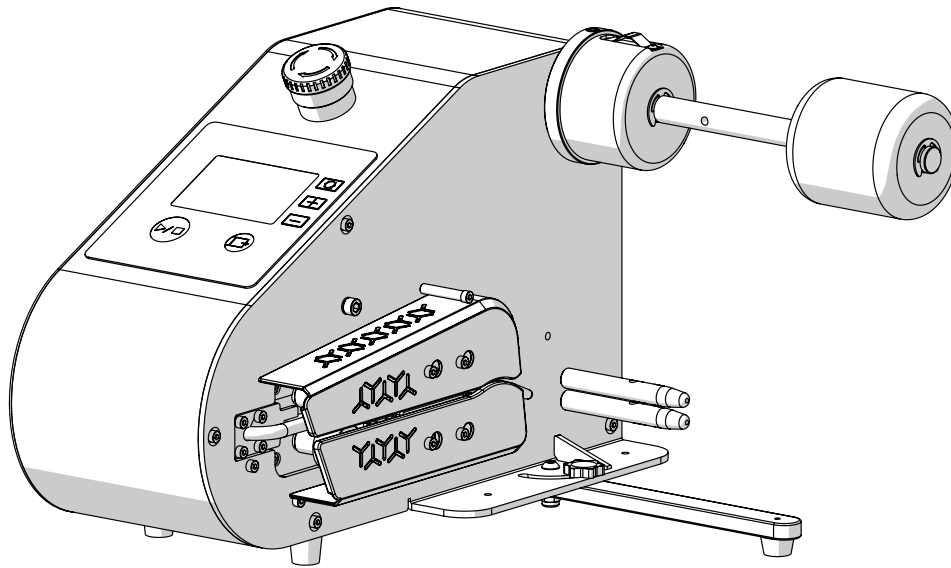


Figure 9: IPG AirSpace 3 Pro<sup>®</sup> for BoD

## Bubble on Demand Accessories

The IPG AirSpace 3 Pro<sup>®</sup> BoD version can be used in coordination with the Bubble Winder. This winder will interface with the IPG AirSpace 3 Pro<sup>®</sup> and produce BoD to a roughly three foot diameter coil. This is useful for preparing and storing premade void fill for several packing stations.

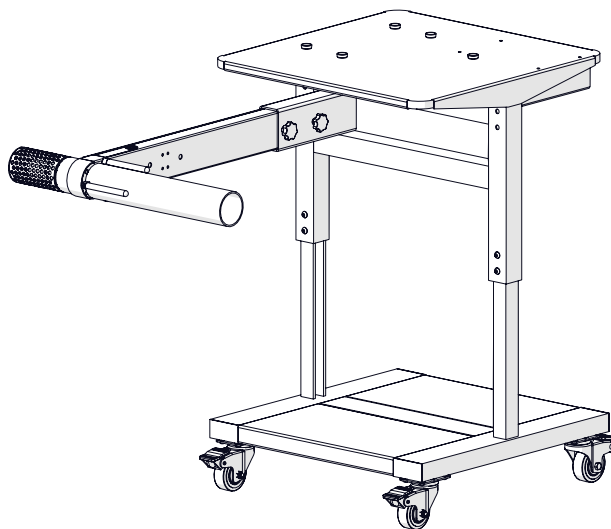


Figure 10: Bubble Winder

# **BUBBLE ON DEMAND**

---

## **Bubble on Demand Settings**

The IPG AirSpace 3 Pro© comes with the settings preset from the factory to meet most use cases for Bubble on Demand. Some adjustment may be necessary from batch to batch on the film. The following are the factory default settings.

Type: 16

Air: 14

Temp: 10

## **Bubble on Demand Film Specifications**

The IPG AirSpace 3 Pro© should only be used with IPG branded film stock supplied from an authorized vendor. Only 12" Bubble on Demand film rolls can be used on the IPG AirSpace 3 Pro©. When a customer has received The IPG AirSpace 3 Pro© that has been configured for Bubble on Demand it cannot be used with traditional air pillows. If you are looking to produce air pillows and only have Bubble on Demand machine please contact your Authorized IPG Representative.

When inflated, bubble sheets will be approximately 12" across, perforation lengths may vary based off of the ordered film.

# BUBBLE ON DEMAND

## Bubble on Demand Film Loading

Loading and threading Bubble on Demand film onto the IPG AirSpace 3 Pro© is very similar to the standard air pillow threading process with the exception of the additional film guide.

1. Ensure any accessories are properly connected to the **Machine's** rear panel.
2. Ensure the Main Power Connection is properly connected to the **Machine** and wall socket.
  - Verify the power cord is not damaged
3. The **Emergency Stop button** is not pressed.
4. Turn the **Machine ON** by switching the **I/O Main Switch** on the rear of the **Machine** to the **[I]** position.
5. Verify the **Machine** settings are set to the desired settings for your film.
6. Place the **Roll of Film** over the mandrel and verify it is fully seated.
  - Film should peel off the roll over the top towards the rear of the **Machine**. Follow the Film Threading Path for details. Film should pass over the front of the upper film guide, between the two guides, and wrap around the rear of the lower film guide before going toward the nozzle. This helps to block air from reaching the main roll and preventing mis-feeds and jams.
7. Place the film air channel over the nozzle of the **Machine** until it reaches the belts.
8. Use the "Film Jog" button (Figure 9) by pressing and holding, to advance the film through the belts of the **Machine**.

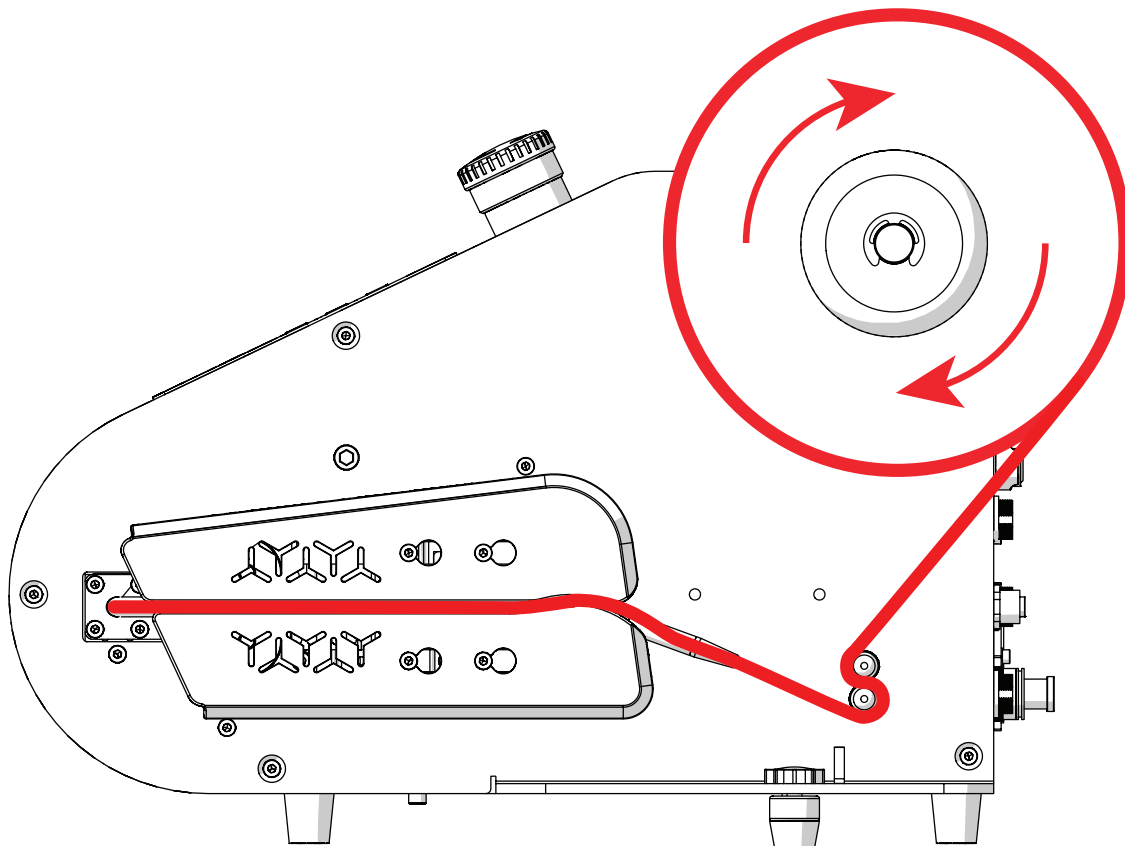


Figure 11: Film Threading Path for Bubble on Demand

# MAINTENANCE

---

## Inspection, Maintenance, and Repair



**WARNING! THE OPERATOR MAY NOT PERFORM ANY MAINTENANCE OR REPAIR PROCEDURES OTHER THAN THOSE THAT ARE WRITTEN AND SPECIFIED UNDER “ OPERATOR WEEKLY INSPECTION INTERVAL ” AND IN THE SECTION “ TROUBLESHOOTING ” WHICH ARE SPECIFICALLY POINTED OUT TO THE OPERATOR IN THIS USER MANUAL.**



**CAUTION! IN THE EVENT OF A DEFECT, OR IF THE OPERATION OF THE MACHINE DIFFERS FROM THE DESCRIPTIONS IN THIS USER MANUAL, TURN THE I/O MAIN SWITCH TO [O] OFF AND DISCONNECT THE MAIN POWER CORD PLUG FROM THE MAIN POWER SOCKET UNTIL THE UNIT CAN BE INSPECTED BY A TRAINED NUEVOPAK, AN IPG COMPANY, REPRESENTATIVE, OR QUALIFIED SERVICE PERSONNEL.**

## Operator Weekly Inspection Interval

This section contains the following **Operator** procedures:

### 1. Weekly Inspection Interval



**Check if:**

- Covers are properly affixed and not damaged.
- Machine cables are not cut, broken, or damaged.
- Cords or plugs are not damaged.
- Machine and accessories components are affixed well.
- All controls and indicators function properly.



**CAUTION! DO NOT OPERATE ANY SYSTEM WITH A DAMAGED CORD OR PLUG, OR AFTER THE SYSTEM MALFUNCTIONS OR IS DROPPED OR DAMAGED IN ANY MANNER. RETURN THE SYSTEM TO THE NEAREST AUTHORIZED SERVICE FACILITY FOR EXAMINATION, REPAIR, ELECTRICAL OR MECHANICAL ADJUSTMENTS.**

## Preventative Maintenance Interval

Preventative maintenance/inspection should be conducted every two months or 50 rolls of film, whichever comes first. The qualified service personnel will inspect and replace any damaged components. Only **qualified service personnel** are permitted to conduct general maintenance and repairs on the **Machine**. Those trained by qualified service personnel, referred to as **trainers** are permitted to conduct the following preventative maintenance on the **Machine**. A service manual with notated **trainer** approved processes can be provided upon request.

General preventative maintenance includes:

- Inspecting belts for wear, replacing when necessary
- Inspecting blade for wear, replacing when necessary
- Inspecting the drive rollers for build up and wear, clean or replacing when necessary
- Verifying the nozzle tip is smooth and free from sharp edges



**PREVENTATIVE MAINTENANCE INSPECTIONS ARE DONE TO MAKE SURE THE MACHINE PREFORMS AT ITS EXPECTED LEVEL. THEY ARE PERFORMED AT INTERVALS OF EVERY 2 MONTHS OR AFTER USAGE OF 50 ROLLS OF FILM.**

# MAINTENANCE

---

## Preventative Maintenance Interval



**WARNING! ONLY QUALIFIED SERVICE PERSONNEL WHO HAVE BEEN TRAINED BY A NUEVOPAK OR IPG COMPANY REPRESENTATIVE ARE ALLOWED TO PERFORM MAINTENANCE AND REPAIR PROCEDURES. BEFORE ANY MAINTENANCE: SWITCH THE I/O MAIN SWITCH TO [O] OFF POSITION AND DISCONNECT THE MAIN POWER CORD PLUG FROM THE MAIN POWER SOCKET.**



**BEFORE PERFORMING MAINTENANCE PROCEDURES READ AND THOROUGHLY UNDERSTAND THE SAFETY INSTRUCTIONS IN THIS USER MANUAL. QUALIFIED SERVICE PERSONNEL WILL HAVE A SERVICE MANUAL ON THE MACHINE.**

1. The void fill air pillows created by the **Machine** are intended to be used only as packaging material.
2. The operator may not perform any maintenance or repair procedures other than specified in **OPERATOR WEEKLY INSPECTION INTERVAL**.
3. Changes or modifications not expressly approved by **Nuevopak, an IPG Company**, could void the user's authority to operate the equipment.
4. In the event the maintenance required is beyond the scope outlined in this user manual, contact **Nuevopak, an IPG Company**, support for a qualified service technician.

# TROUBLESHOOTING

## General Troubleshooting

The **Machine** is intended to be used for converting rolls of film into void fill air pillows. Repairs or modifications should be done by a **Nuevopak**, an **IPG Company**, authorized representative or **Nuevopak**, an **IPG Company**, trained Service Technician; refer to [Technical Support](#).

Problem	By Whom	Possible Causes	Solutions
There is no power to the Controls – the LCD screen does not light up.	Operator	1. The <b>I/O Main Switch</b> is positioned to the <b>[O] OFF</b> position.	The <b>I/O Main Switch</b> to the <b>[I] ON</b> position.
		2. <b>IEC Main Power Cord Connection</b> or <b>Power Cord Plug</b> is unplugged from the back of the <b>Machine</b> or at the <b>Wall Socket</b> .	Verify the <b>IEC Main Power Cord</b> connection is plugged into the <b>Machine</b> and the <b>Power Cord Plug</b> is plugged into properly rated Wall Socket.
		3. The <b>Emergency Stop</b> is engaged.	Rotate the emergency Stop button 1/4 turn clockwise to disengage.
	Service Technician	4. <b>Main Fuse</b> is defective.	Turn the <b>I/O Main Switch</b> to the <b>[O] OFF</b> position. Disconnect the <b>Main Power Cord Plug</b> from the main power. Replace with a 10A 250V 5X20mm (3/16" X 3/4") fuse.
		5. A <b>cable reel</b> is in use.	Replace the cable reel with an extension cable with a wire gauge of at least 14 AWG (1,5mm <sup>2</sup> ) with a maximum length of 11.5 ft. (3.5 m).
		6. <b>Electrical</b> or <b>Mechanical</b> defect.	Contact your authorized distributor or <b>Nuevopak</b> , an <b>IPG Company</b> representative.
		7. Display shows <b>B1 Error</b> .	Engage the Emergency Stop and disconnect from all energy sources and contact your authorized distributor or <b>Nuevopak</b> , an <b>IPG Company</b> , representative.
Air Pillows are not being produced. <b>C1 Error</b> .	Operator	1. The <b>film roll</b> has been depleted.	Reload the <b>Machine</b> with a new <b>Roll of Film</b> . Follow the film threading path (Figure 6) for proper threading.
		2. A <b>film jam</b> has occurred.	1. Remove the film from between the belts. Reload the film. 2. If jam continues to occur, contact your authorized <b>distributor</b> or <b>Nuevopak</b> , an <b>IPG Company</b> , representative.
	Service Technician	8. The nozzle is not aligned to the encoder wheel.	Follow the procedure to reset the nozzle. Contact <b>Technical Support</b> if unable to complete.



# **USER NOTES**

---

